

Archaeological excavations at Lungi Tapa, south Uzbekistan. Report for Season 2021

Ladislav Damašek – Daniel Pilař – Samuel Kertés – Shapulat Shaydullaev

ABSTRACT

This report summarises the preliminary results of the second season of excavations at the site of Lungi Tapa in the Kugitang Piedmonts, south Uzbekistan. The research was conducted by a Czech-Uzbek team in autumn 2021. The results suggest that the site was settled in the post-Kushan period, the Early and High Medieval period with traces of settlement from the Late Medieval period. Later it was used as a burial ground for the local population. Traces of metal production were found at the site.

KEYWORDS

Central Asia; Tokharistan; Lungi Tapa; High Medieval Period; Early Medieval Period; archaeology; excavation; settlement; stratigraphy; metal production.

INTRODUCTION

The High Medieval period in the Kugitang Piedmonts is not very well covered by archaeology and history. Only a few sites from this period have been excavated so far in the area (BOBOKHOJAEV – ANNAEV – RAKHMANOV 1990; MOKROBORODOV 2007; ŠEJKO 2011). Lately, an extensive field survey was carried out by the Czech-Uzbek archaeological expedition in the Kugitang and Hissar piedmonts confirming many of the previously found sites as well as discovering new ones (DAMAŠEK 2019, 48). Based on our works (corroborating the opinions of other scholars) there was a significant growth in population in the High Medieval period in this region (STRIDE 2004; AUGUSTINOVÁ *et al.* 2016; STANČO 2019). This can partly be attributed to the exploitation of metals, traces of which were found in the area of the Kugitang and Hissar piedmonts (STANČO *et al.* 2019, 145, 162). But a closer look at both the archaeological and historical evidence is needed to get a better understanding of the processes which led to the rapid settlement growth in the High Medieval period.

The Czech-Uzbek expedition commenced its field work on the site of Lungi Tapa in 2019 and in 2021 after a one-year break came back to finish the work. In 2019, four main phases of the settlement were established based on the stratigraphy but neither the lower levels of the settlement nor the subsoil were reached (DAMAŠEK *et al.* 2020). The main phases contained a settlement of the High Medieval (from the Arab phase to the Mongol invasion, 8th–13th century AD) and the Early Medieval periods (5th–8th century AD), as well as a 16th–18th century AD burial ground. The team working on the site in 2021 consisted of archaeologists from Charles University, namely Ladislav Damašek, Daniel Pilař, and Samuel Kertés. The work was done under the auspices of the Czech-Uzbek archaeological expedition led by Shapulat Shaydullaev (Termez State University) and Ladislav Stančo (Charles University). Kachraman Toshaliyev (Termez State University) provided logistic and administrative support for the expedition. Four local workers from the village of Khojaunkan participated in the excavations as workers.

LOCATION

Lungi Tapa is located on the eastern edge of the modern-day village/micro-oasis of Khojaunkan (**Fig. 1**) in the Kugitang foothills (Sherobod District, Surxondaryo Province). The village of Khojaunkan (37°53'48.549"N, 66°46'33.414"E) is situated approximately 30 km as the crow flies from Sherobod town. The site Lungi Tapa consists of a central mound and a platform surrounding it. The central mound (tell settlement, in local terminology tepa) has an oval shape with dimensions of roughly 60 × 40 m at the base (**Fig. 2**). The average height of the central mound is approximately 6.5 m. The platform has a clear border on the eastern and partly on the northern side, but on the southern and western side it is disrupted by contemporary houses and other minor constructions such as fences and outbuildings. Thus, it is difficult to define its precise original shape and area.

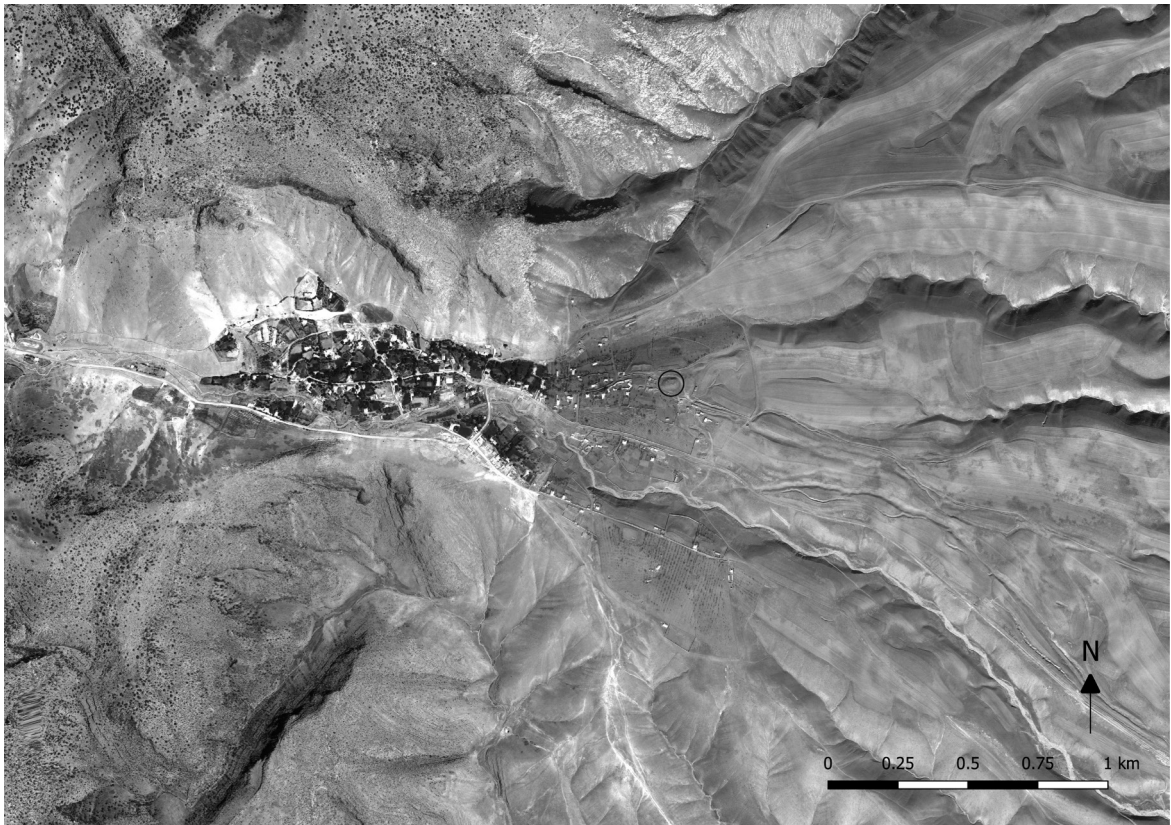

Fig. 1: Location of Lungi Tapa inside the village/micro-oasis of Khojaunkan (L. Damašek).

PREVIOUS ACTIVITIES

Lungi Tapa was known by local archaeologists from the 1980s when the first archaeological research was carried out at the site (BOBOKHOJAEV – ANNAEV – RAKHMANOV 1990). The Czech-Uzbek expedition first took an interest in the site in 2017. A surface survey was carried out and dating of the site to the Medieval period was confirmed (STANČO *et al.* 2017). In 2019, a team consisting of anthropologists led by Rebecca Kinaston (University of Otago, NZ) and archaeologists led by Ladislav Damašek (Charles University, CZ) selected the site for a trial

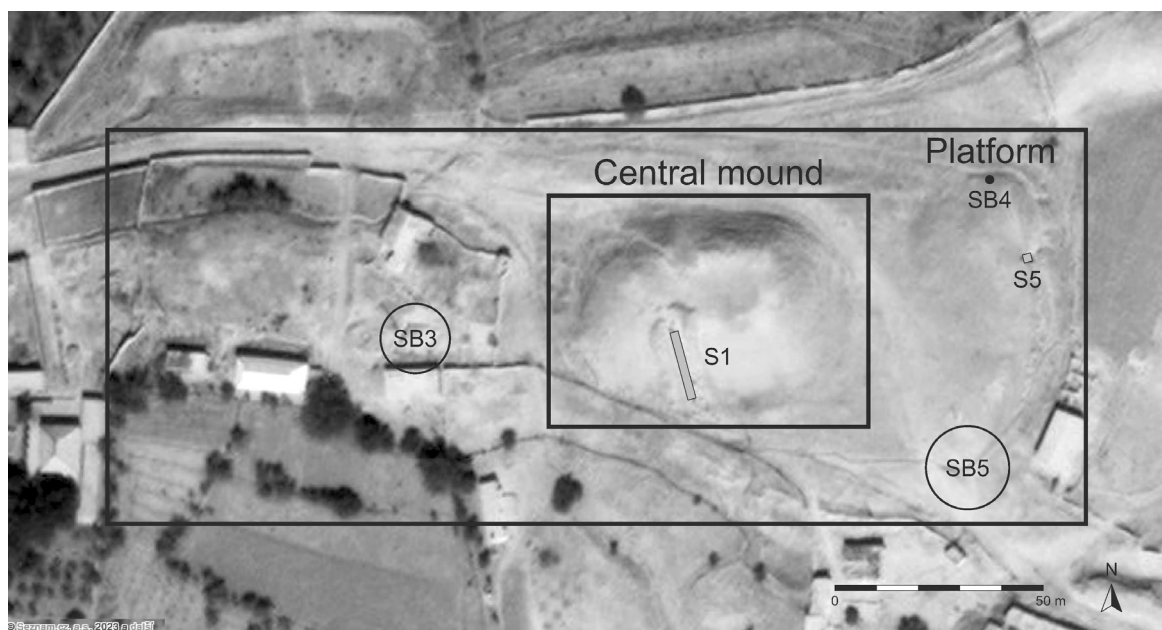

Fig. 2: Map of the Lungi Tepas site (L. Damašek).

excavation, whose preliminary results have been published (DAMAŠEK *et al.* 2020). However, the excavation of the site was not finished in 2019. This was mainly because the main tell mound was used as a cemetery in later historical periods (which had not been anticipated) and the excavation of the graves took up much of the field work time. In autumn 2021 after a one-year break caused by covid restrictions, the members of the Czech-Uzbek expedition returned to Lungi Tepas to finish the excavations started in 2019.

SURVEYED AREAS

In 2021, the main goal of the Lungi Tepas team was to finish the stratigraphic section of the central mound (trench S1), which was started in 2019. In addition to S1, four new areas were explored in 2021 around the central mound of Lungi Tepas, namely S5, SB3, SB4, and SB5 (Fig. 2). The last three mentioned trenches are spots where pottery was collected from the surface of the platform. No systematic approach was used for collecting the pottery shards. SB3 and SB5 are spots where the platform was disrupted by recent human activity. SB3 is a place of clay extraction located in a garden to the west of the central mound of Lungi Tepas. It is in the vicinity of the test pit S2 from 2019 and it was dug deep into the platform. Pottery was collected from the walls of this clay extraction site. SB5 is a shallow hollow way on the southeast edge of the platform. In this place a dirt road crosses the edge of the platform causing erosion. Pottery shards were collected in and around the hollow way. SB4 is a place indicated by local inhabitants as the find spot of a complete ceramic vessel (Fig. 3). S5 is located on the eastern edge of the platform, its main objective was to explore/examine the structure and stratigraphy of the platform. The platform has a steep slope on the eastern side which was disrupted by clay digging for a nearby mud fence wall (Fig. 4). We took advantage of this disruption and the existing profile was simply straightened to see if the basic stratigraphy can be determined. Its final depth as well as width was approximately 2 m (Fig. 4). Pottery shards were present only in the upper 20 cm of soil. The assumption that the basic stratigraphy of the platform

would be revealed through the cleaning of an existing terrain disruption was not confirmed. In order to get more information about the nature of the platform, a stratigraphic section or broader excavations are needed. Such an undertaking was not possible given the time limitations of the Lungi Těpa team.



Fig. 3: A vessel found by local inhabitants in the find-spot SB4 (photo by S. Kertés).



Fig. 4: Trench S5 before and after excavation (photo by L. Damašek).

TRENCH S1

In 2019, the bottom of trench 1 was covered with a plastic sheet and then backfilled with soil at the end of the excavation. In 2021, the soil was removed to the level of the plastic sheet and then the excavation work continued deeper into the Lungi Těpa main mound. On its southern side the trench S1 was extended (from 9 m in 2019) towards the base of the central mound up to approximately 16.4 m. Its width of 2 m and orientation to the cardinal direction was maintained. The final dimensions of S1 were thus 16.4 m in length, 2 m in width, and almost 4 m

in depth (in the northern part). Two baulks labelled K1 and K2 were left in the north part of S1 and a test pit labelled R1 was excavated in the southern part of S1. All the digging was done manually using hand tools. A metal detector was used to check both the excavated soil and the excavated levels inside S1. Grave filling and selected contexts were sieved using a 2 mm sieve. S1 as well as other places subject to excavation were measured (location, altitude) by total station. Topographical reference points created in 2019 were used to set up the total station. Therefore, the 2021 measurement should have the same accuracy/error as that of 2019. Photographic documentation was made along with drawings of selected situations. Selected situations were also documented for 3D models.

The pottery from stratigraphic unit PI was counted and weighed. Selected shards from PI (rims, decoration, etc.) were labelled, photographed, and drawn. All the pottery from the rest of the stratigraphic units was labelled, photographed, and drawn without exception. All other finds (bones, glass, stone, metal, and others) were counted photographed and in some cases drawn.

EXCAVATED UNITS

The newly uncovered southern part of S1 yielded contexts from all the four recognised phases (PI, PII, PIII, PIV) already distinguished in 2019 (DAMAŠEK *et al.* 2020). In the original part of S1, work continued from the level of PIII/PIV. In 2021, a new phase labelled PV was recognised. Subsoil was reached in the southern part of S1 by the base of the tepa. Graves (= PII) were expected in the newly excavated (southern) part as they were present underneath surface layers (PI) in 2019 and greater attention was paid to their identification.

PI

The trench was dug from the surface by spits until any distinguishable features were found. All these units belong to the phase PI, the depth of which varies depending on the stratigraphy preserved underneath. Logically, it is thicker at the base of the tell mound due to the erosion. A number of small metallic finds was detected by metal detector in the contexts of this phase (**Tab. 1; Fig. 18:52, 18:56**). Terracotta figurines of a bird and of another undetermined animal were found among the material of this phase (**Fig. 2:4-5**). In 2019, a Subphase IA (PIA) was established (DAMAŠEK *et al.* 2020, 166). After revisiting the situation, this subphase was cancelled and the pit (labelled OBJ12), which was its only component, was reassigned to phase III.

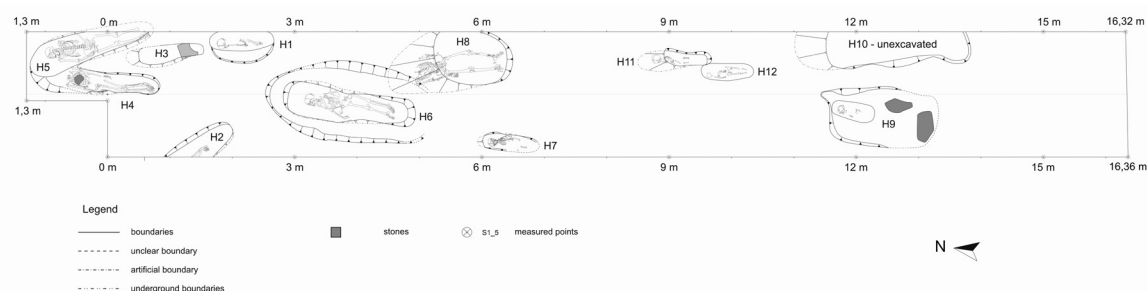

Fig. 5: Graves (drawing by L. Damašek).

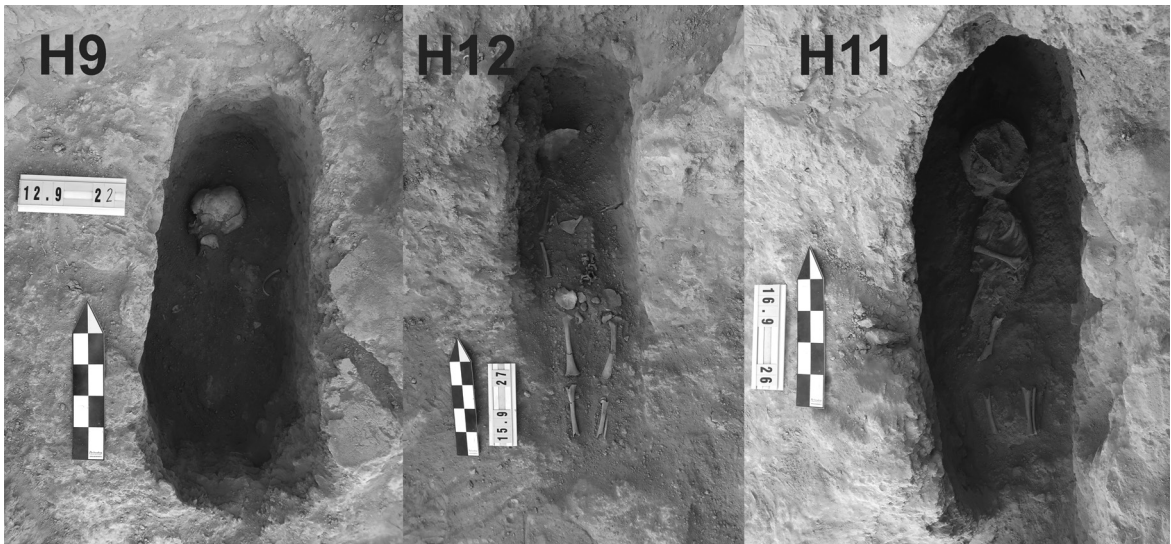

Fig. 6: Graves H9, H11, and H12 (photo by L. Damašek).

P11

The excavation started by removing the surface layers in the newly (2021) uncovered southern part. Beneath these layers, four graves were found: H9, H10, H11, and H12 (**Fig. 5-6**). Three of them were children's burials (**Fig. 6**) and one was probably an adult. The children's graves (H9, H11 and H12) were excavated but not the adult one (H10). Its depth and position allowed the skeleton to be left untouched without interfering with work on the stratigraphic section. Just the upper part of the H10 grave-pit and filling was removed, while the skeleton was left intact. Thus, the assumption that it is an adult grave is based entirely on the dimensions of the grave-pit. All the graves have an identical south-north orientation with the head facing west (which could be only assumed in the case of H10). There were no grave goods and the grave pits were relatively narrow. H9 was covered by flat stones and two pieces of what were probably tiles (**Fig. 7**). H10 had stones inside the grave backfill. H11 and H10 had a niche dug in their northern part (**Fig. 5**). H11 and H12 were in mutual superposition. H11 disrupted the southernmost part of H12 (**Fig. 5**). All the graves were disturbed by bioturbation namely by mice. Mouse holes together with an abundance of mouse bones were found in all the grave fillings (**Fig. 8**). The three children's graves (H9, H11, and H12) were in each case incomplete, parts of the skeletons were missing.



Fig. 7: Grave H9 with and without stone cover (photo by L. Damašek).



Fig. 8: Mice bones inside H11 (photo by L. Damašek).

There were no factors, which would suggest that these graves were not associated with those (H1–H8) previously found in 2019. Therefore, all the graves (H9–H12) from 2021 were assigned to the phase PII. This phase is represented by a burial ground which covered at least the central mound of Lungi Tepa. Two graves H4 and H5 of PII from 2019 were dated using the radiocarbon method. In both cases a rib bone was used for the dating. The sample from H4 was dated between 1510–1660 AD and the sample from H6 between 1460–1640 AD (Fig. 9:1–2). Thus, the burial ground can be roughly dated to the time span from the 15th–17th century corresponding to the period of the Uzbek and Bukhara khanate. It is worth noting that from 12 graves detected in 2019 and 2021 seven were children’s graves and only five belonged to adults.

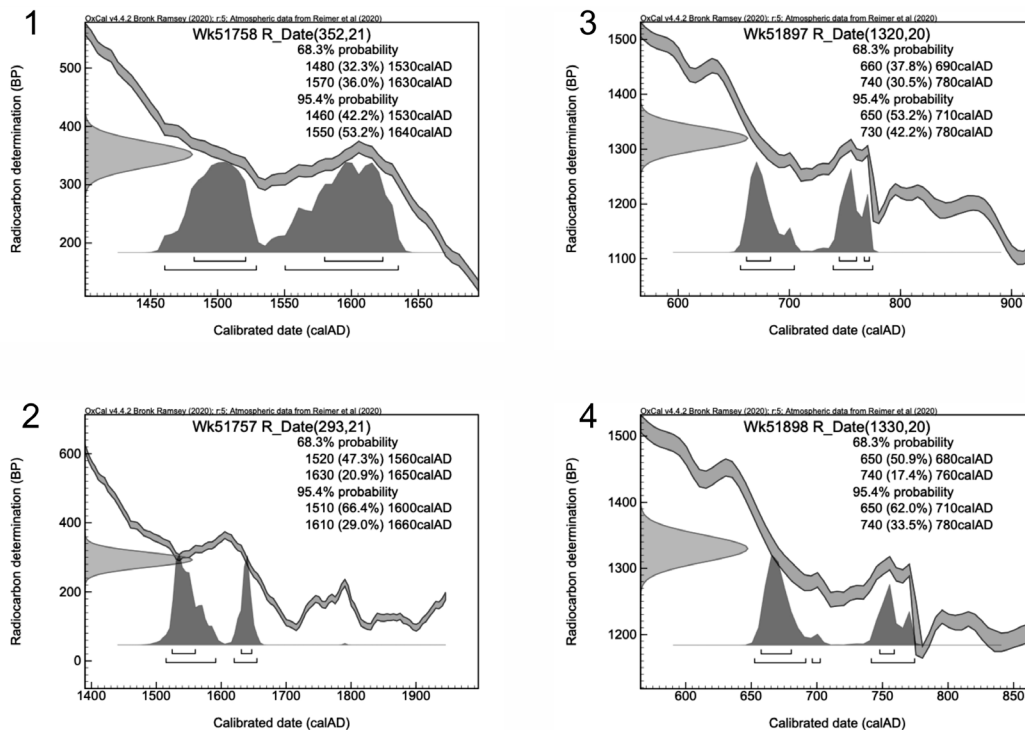

Fig. 9: Radiocarbon dating of H4, H5 and two pieces of cow bones from layer 13.

PIII

The graves overlie the horizon PIII established in 2019 and consist of all features from the Islamic period (High Medieval period; 8th–13th century AD). The remains of a *pakhsa* (rammed clay) wall (OB8) remained in the northern part of S1 (**Fig. 11–12**). The remains of the wall were dismantled in 2021, and a new feature was recognized which was not identified in 2019. It was probably a round pit with a flat bottom (labelled 24) which was cut into the *pakhsa* wall – OB8 (**Fig. 11**). Its eastern part remained unexcavated, because it was beyond the eastern profile of S1 and its southern part was destroyed by the grave-pit of grave H8. Its relation with the upper layers remains uncertain, but being cut by a grave-pit (phase PII) and containing pottery similar to pottery collections from PIII, the pit (feature 24) was assigned to PIII. The base of OB8 was found, it formed a flat surface which was easily recognisable because the clay blocks break off from it (**Fig. 10**). The base of OB8 was the upper part of the foundation of OB8 (labelled 30) which was hardly recognisable during the excavation but was very well distinguished on the profiles especially on the western one (**Fig. 12**). The above-mentioned features were the remains of PIII in the part of S1 excavated in 2019. Other features from PIII were excavated in the part of S1 uncovered in 2021. The most significant of these were the remains of three walls (labelled 25, 28, and 34), a storage pit (labelled 39) and several horizontal layers (labelled 32, 501, and 502). Walls 25 and 28 were in superposition and they followed the contours of the main tell mound (**Fig. 11–12**). It looked like they formed rings around the main tell mound, but it is hard to draw any conclusion from the 2 m wide trench. Wall 25 was made of stone (**Fig. 13**) and it cut through wall 28, whereas wall 28 was recorded only as negative in the form of a ditch. On the eastern side, both walls were disturbed by two children's graves H11 and H12. Underneath walls 25 and 28, layer 32 followed which contained a great many pottery shards. Layer 32 continued south to the base of the tell mound where it lay on layer 37 and subsoil (**Fig. 11**). In the south part of S1 a test pit labelled R1 was placed to check the depth of the subsoil (**Fig. 12, 14**). The filling of the test pit labelled 400 was excavated in one go. Only after that, layers 32 and 37 were distinguished in the profile inside R1. The remains of a wall (34) were located underneath layer 32 at the base of the tell mound. It was a *pakhsa* wall but only a small piece of it was preserved. It is best visible on the western profile (**Fig. 15**). Wall 34 did not go through the entire width of S1 but it ended in the middle of S1 where it was cut by storage pit 39. In the eastern part of S1 in the place of 34 there is already subsoil (**Fig. 11**). Small finds from the contexts of PIII with the exception of storage pit 39 include small glass fragments, an arrowhead, and a piece of nacre (**Tab. 1; Fig. 18:57; Pl. 4/1:6–10**).



Fig. 10: Clay wall OB8 (photo by L. Damašek).

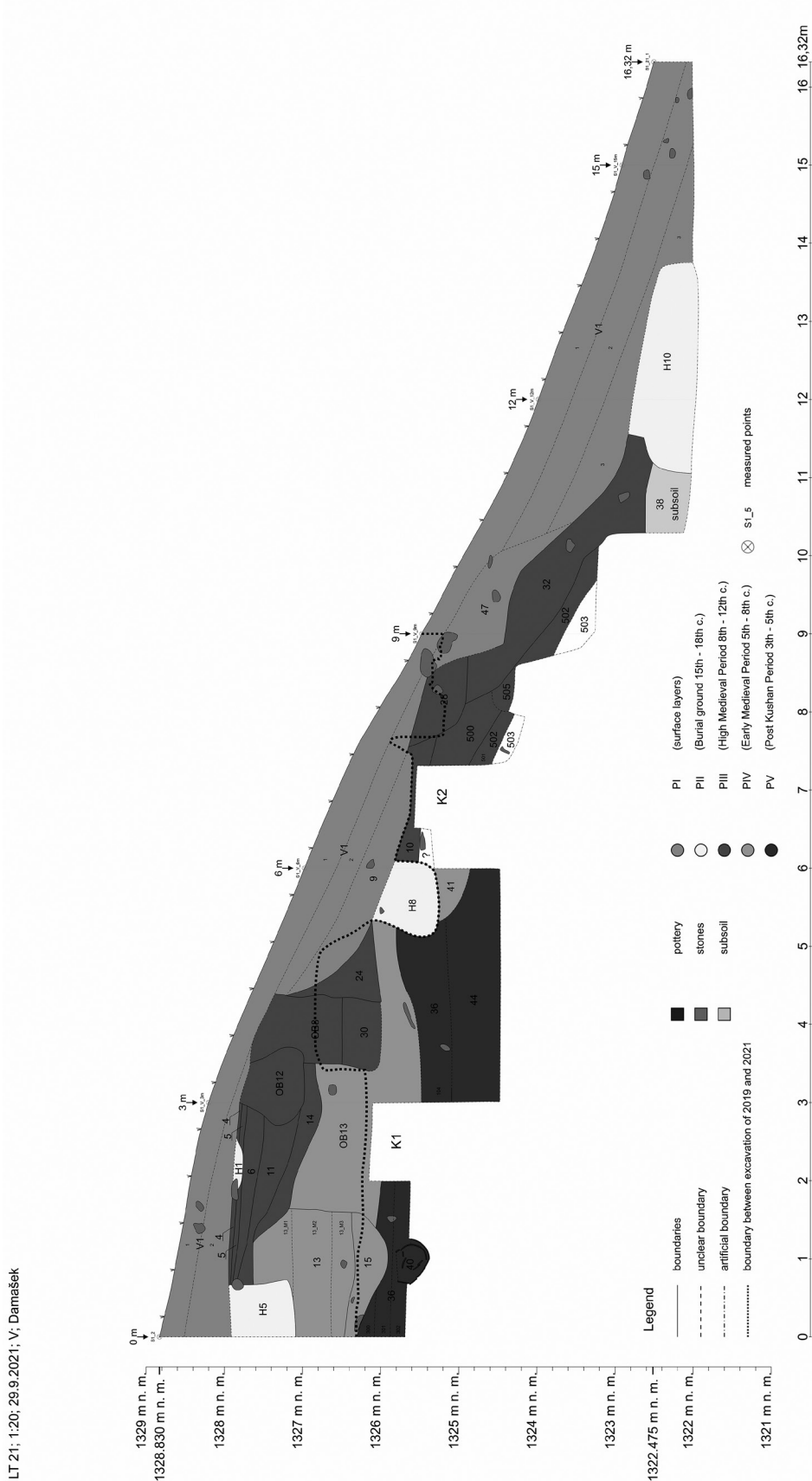

Fig. 11: Eastern profile of S1 (drawing by L. Damašek).

LT 21; 1:20; 29.9.2021; Z; Damašek

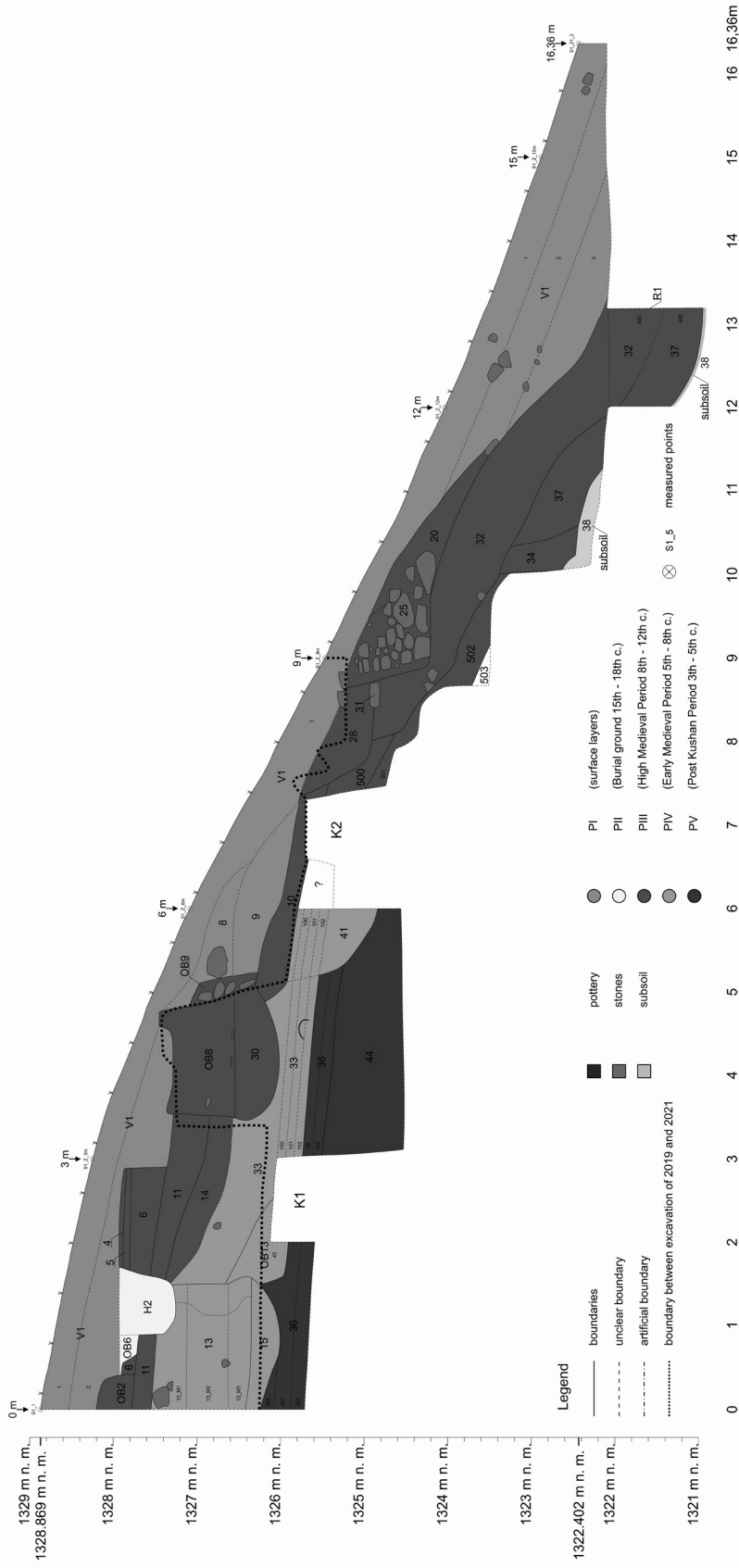

Fig. 12: Western profile of S1 (drawing by L. Damašek).

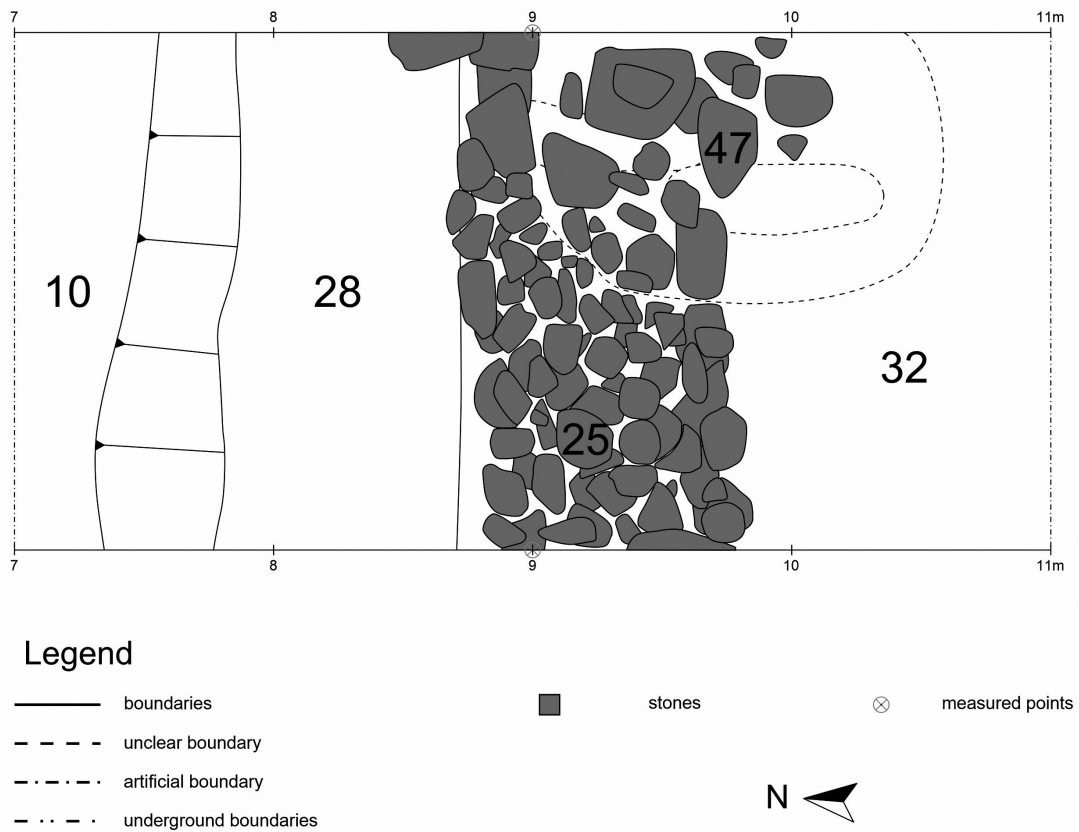

Fig. 13: Stone wall 25 (drawing by L. Damašek).



Fig. 14: Test pit R1 (photo by L. Damašek).



Fig. 15: Clay wall 34 on western profile (photo by L. Damašek).

The most interesting feature found in 2021 was the storage pit labelled 39 (**Fig. 16-17**). It had roughly a conical shape with a flat bottom, a diameter of 110 cm at the bottom and 60 cm at its upper part and a depth of 120 cm. It was excavated by spits with a thickness of 40 cm (labelled 200, 201, and 202) because no actual layers were recognized. The whole filling of the storage pit was sieved using a 2 mm sieve. A part of the filling of the storage pit (approximately 20 kg) was taken for flotation. Because of the sieving and flotation, a small collection of glass fragments was captured together with several beads and metal objects (**Tab. 1**). Among the metal objects there was one distinctive piece, a belt part (**Fig. 18:55**). The glass collection is composed of thin-walled fragments including several rims (**Pl. 4/1:3-5**), two of which were bent inward (**Pl. 4/1:3-4**). The inward bent rims have analogies in material from Termez dated to the High Medieval period, the 8th-13th century AD (ABDULLAYEV 1998, tab. 4). Overall, six beads were found. Four black glass beads (**Fig. 19**) with dimensions between 1-3 mm were obtained by flotation because they were too small for the 2 mm sieve. One transparent bead decorated with blue dots (L. 0.8 cm; D. 1 cm) and one orange bead (L. 0.8 cm; D. 1.1 cm) were found by sieving (**Pl. 4/1:1-2**). In both, the transverse holes were drilled from two directions meeting in the middle. The backfill storage pit yielded also an abundance of pottery. The absence of distinguishable layers inside the storage pit was confirmed also by the ceramic assemblage, because fragments from different spits (200, 201, and 202) were parts of the same vessels. One sample of carbonized seeds (*Triticum spelta*) from the flotation of the filling of storage pit 39 was dated by the radiocarbon method to the time span of 892-1020 AD (**Fig. 20**).



Fig. 16: Storage pit after excavation (photo by L. Damašek).

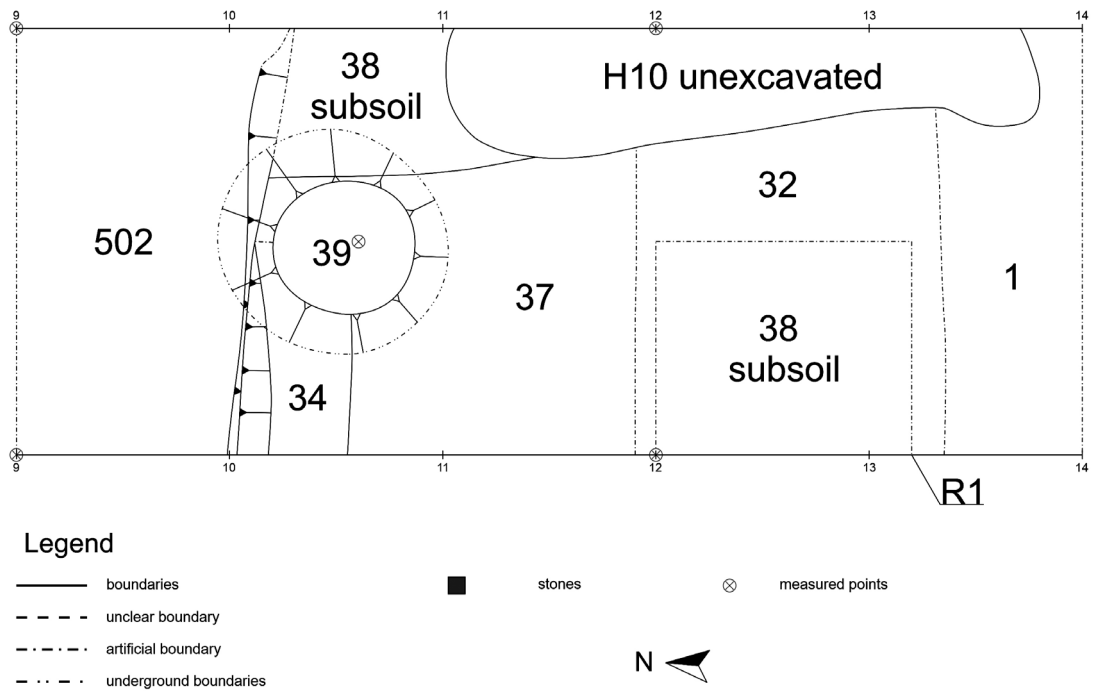

Fig. 17: Storage pit location in S1 (drawing by L. Damašek).

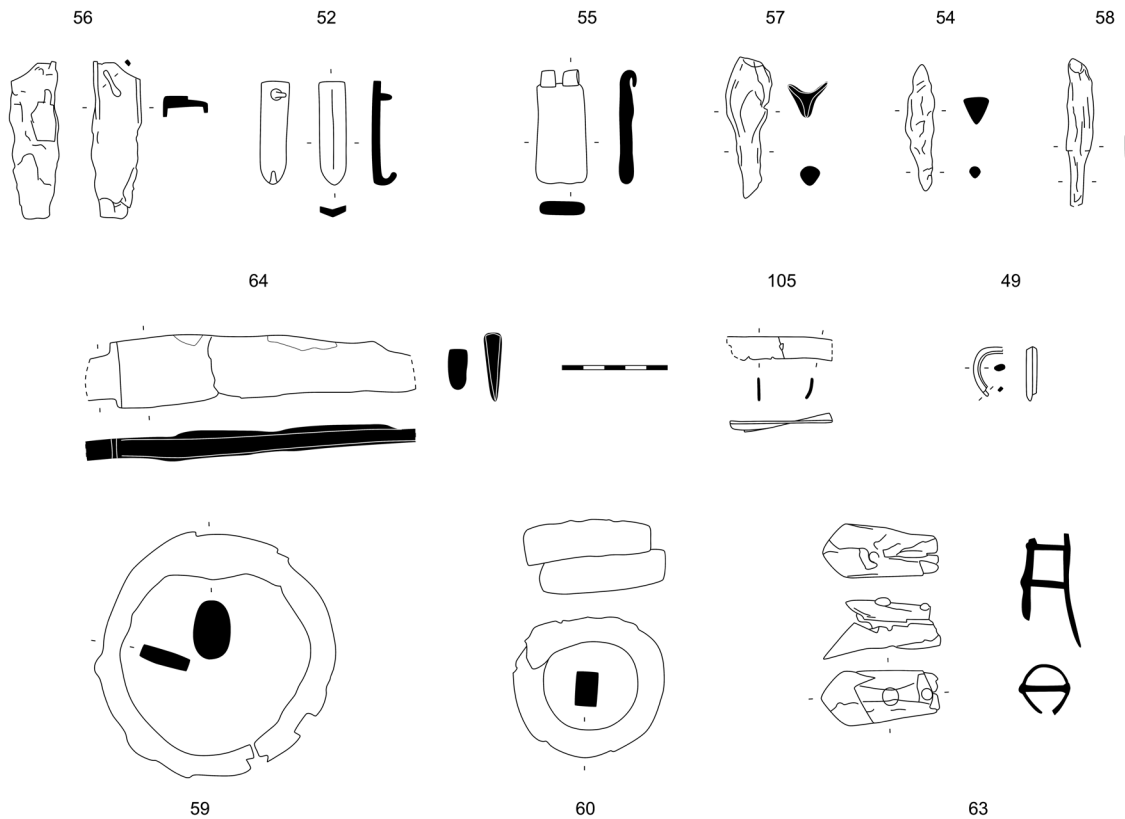

Fig. 18: Metal objects (drawing by L. Damašek).

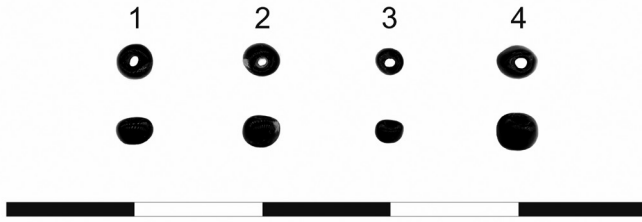

Fig. 19: Small glass beads from the storage pit (photo by L. Damašek).

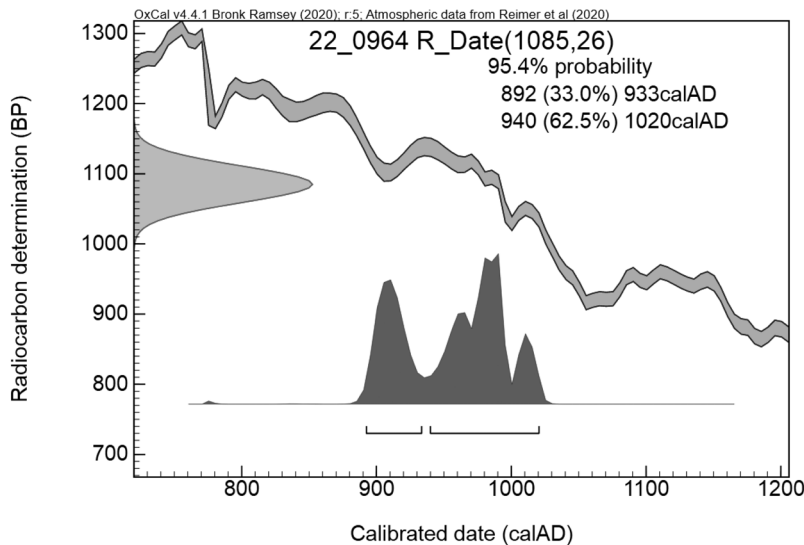

Fig. 20: Radiocarbon dating of carbonized seeds of *Triticum spelta* from the storage pit.

Both larger beads were examined to see if they are made of stone or glass by Raman microspectroscopy using a dispersive spectrometer DXR (Thermo Scientific) coupled to a confocal microscope (Olympus) at the following conditions: unpolarised red 633 nm He-Ne gas laser, 100× objective and 8 mW laser power level. Because it was assumed that it could be varieties of quartz, the quartz spectrum from Šobov near Banská Štiavnica (Collection of the National Museum, Prague, P1N 86.564) was used as a reference spectrum. A very good fit of the Raman spectra of both objects and the reference quartz makes it possible to state that both objects correspond to quartz (**Fig. 21**). The claim that the beads are not made of glass can be further supported by the fact that the holes in the beads are drilled from two sides, whereas glass beads have only a single perforation (KRÖGER 1995, 190). Varieties of quartz cannot be distinguished based on the spectrum. Thus, the determination was made on the basis of the macroscopic appearance. The transparent bead is rock crystal and the orange bead is chalcedony – carnelian. Both stone beads have analogies in material from Nishapur in the collection of the Metropolitan Museum of Art dated to the High Medieval period 8th–13th century AD.¹ The black glass beads also have analogies in material from Nishapur dated to the High Medieval period 8th–13th century AD (KRÖGER 1995, 192–193, 257), but none of the beads from Nishapur have such tiny dimensions.

1 <https://www.metmuseum.org/art/collection/search/450856> (visited 20/07/2023).

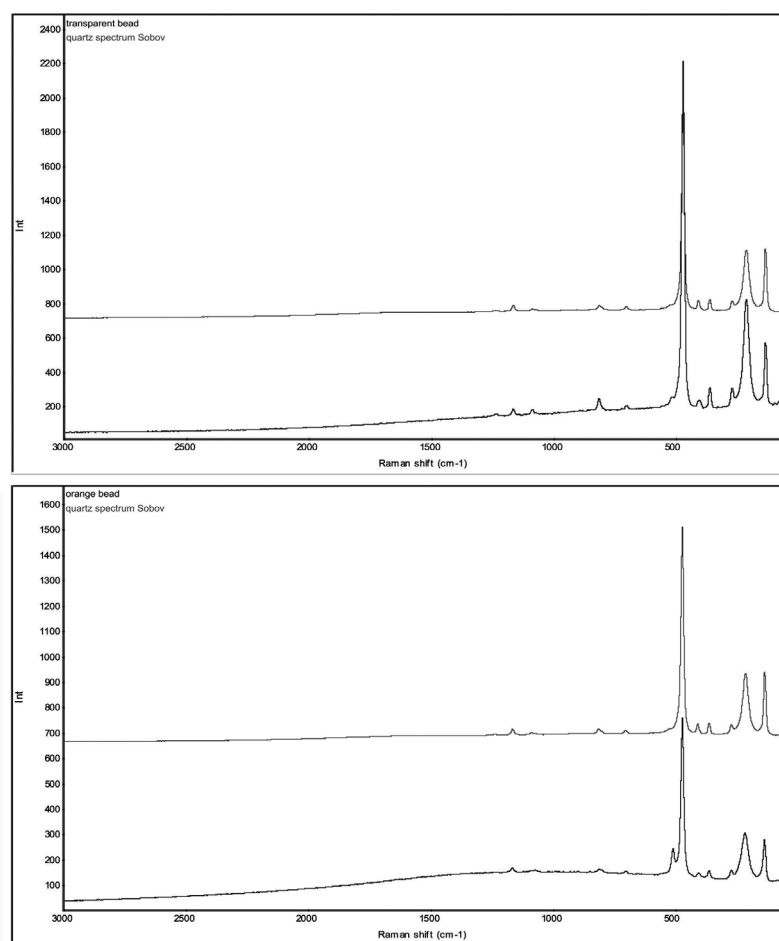

Fig. 21: Raman spectra of beads compared with quartz spectrum.

Several vessels were partly reconstructed from the filling of the storage pit as mentioned above. These include small beakers, a small pitcher, a pot, and a basin with horizontal handles all handmade and a wheel thrown lamp (**Fig. 22:1, 2, 3, 8, 9**). Pottery from the storage pit also includes horizontal handles, several fragments of lids including one whole lid and several rims and bases (**Fig. 22, 23**). Engraved decoration is common in this assemblage. Three glazed fragments were captured including splashed sgraffiato ware, green monochrome glaze, and white opaque glaze with splashes (**Pl. 4/2:1-3**). A terracotta figurine of a horse, a U-shaped terracotta object, and two pieces of what were probably structural elements were present in the assemblage as well (**Fig. 24:1, 3, 7, 8**).

Overall, the pottery collection from PIII does not differ between the years 2019 and 2021. The 2021 collection includes glazed (**Pl. 4/ 2-3**) and unglazed ware (**Fig. 22, 23, 25, 26, 27**). The glazed ware is solely wheel thrown whereas the unglazed is wheel thrown or handmade. Handmade ceramics slightly predominate in the 2021 assemblage (56%, 463 fragments). The types of decoration include engraving, painting, attached, moulded, stamped, carved, and glazed. The basic division of glazed pottery is between monochrome and polychrome ware. The polychrome ware was represented by underglaze slip painted ware with or without incisions and bichrome opaque ware. The monochrome ware was both transparent and opaque. The main decoration groups present in the assemblage include splashed sgraffiato ware

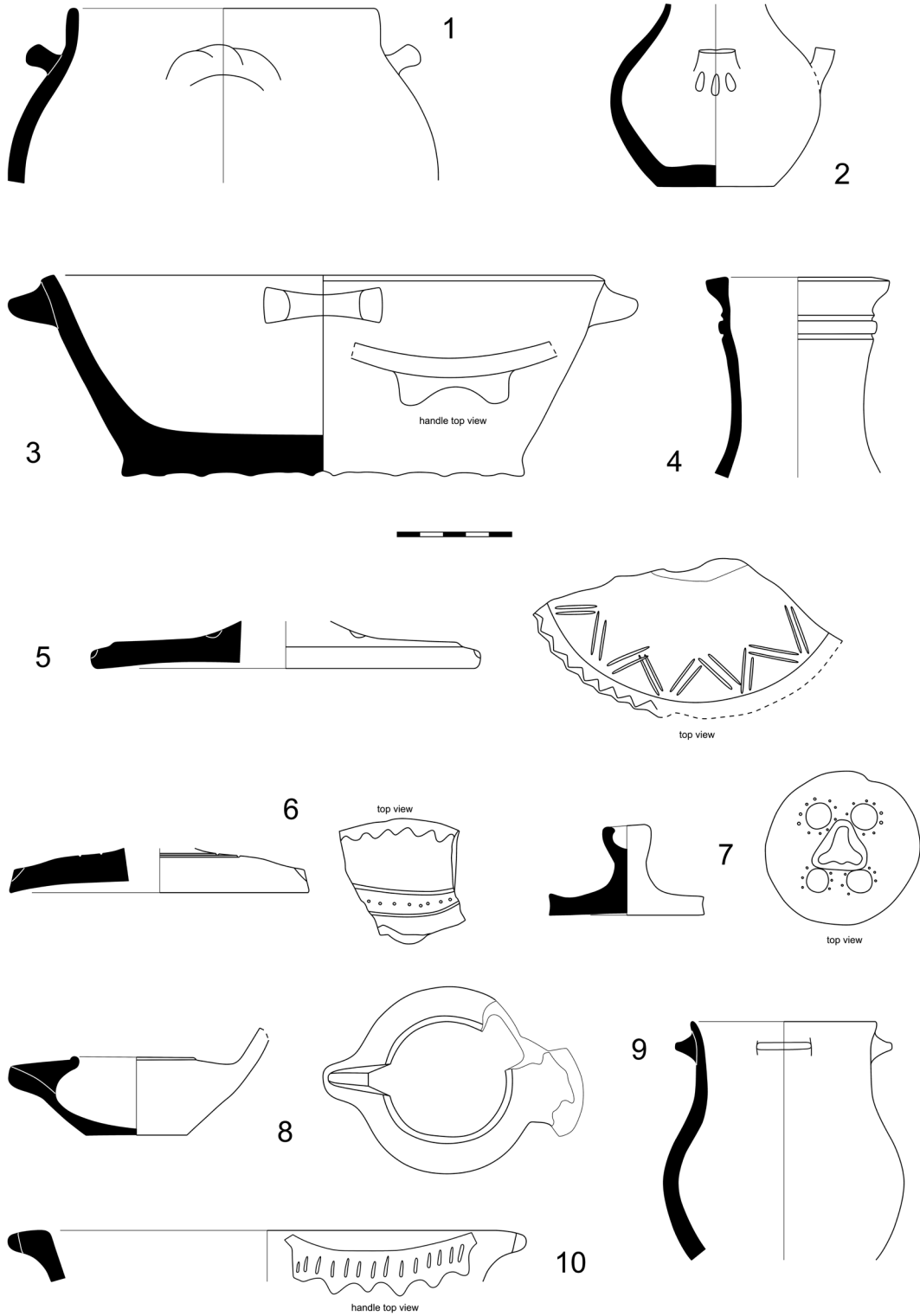

Fig. 22: Pottery phase III - storage pit (drawing by L. Damašek).

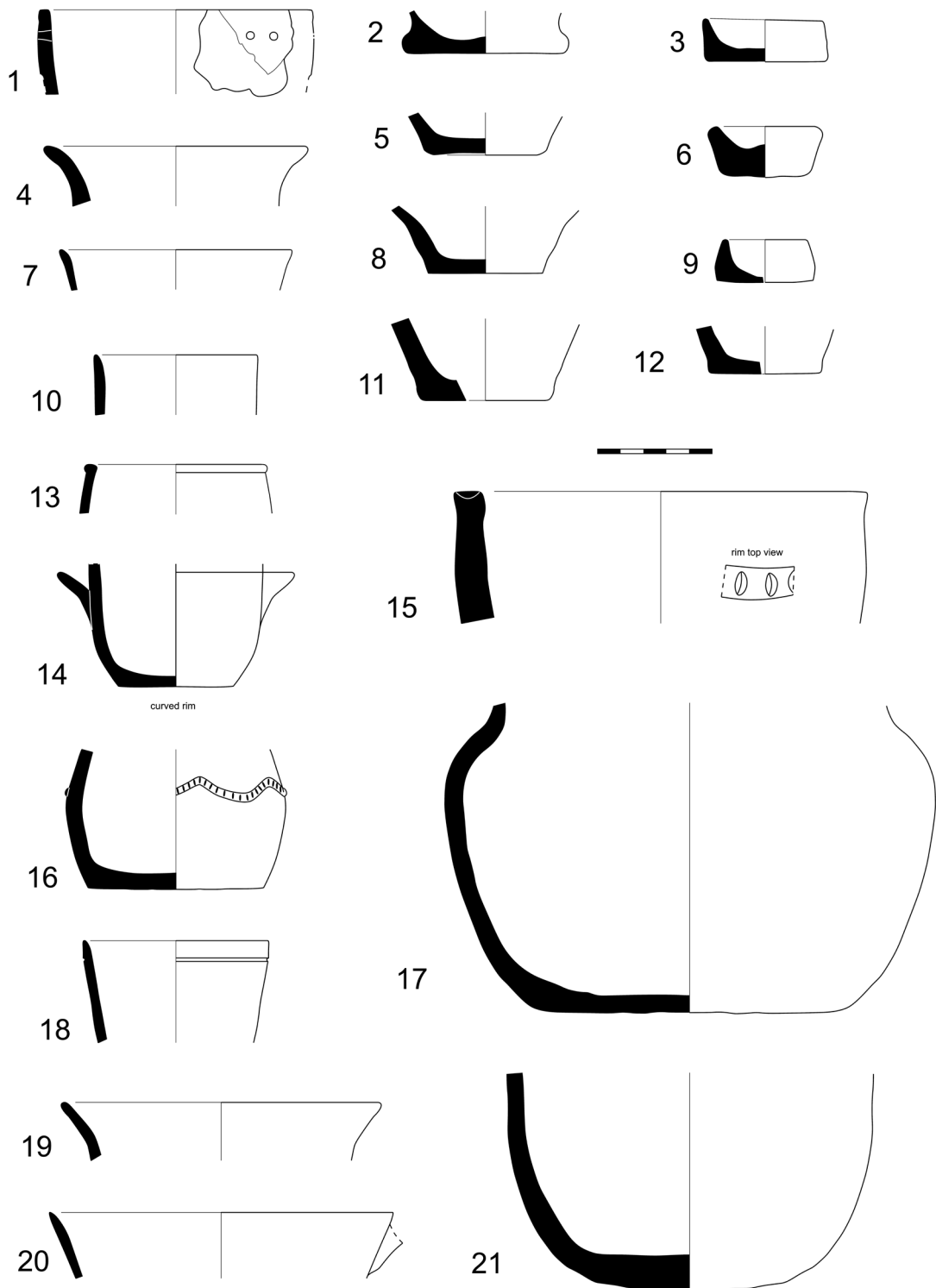

Fig. 23: Pottery phase III - storage pit (drawing by L. Damašek).

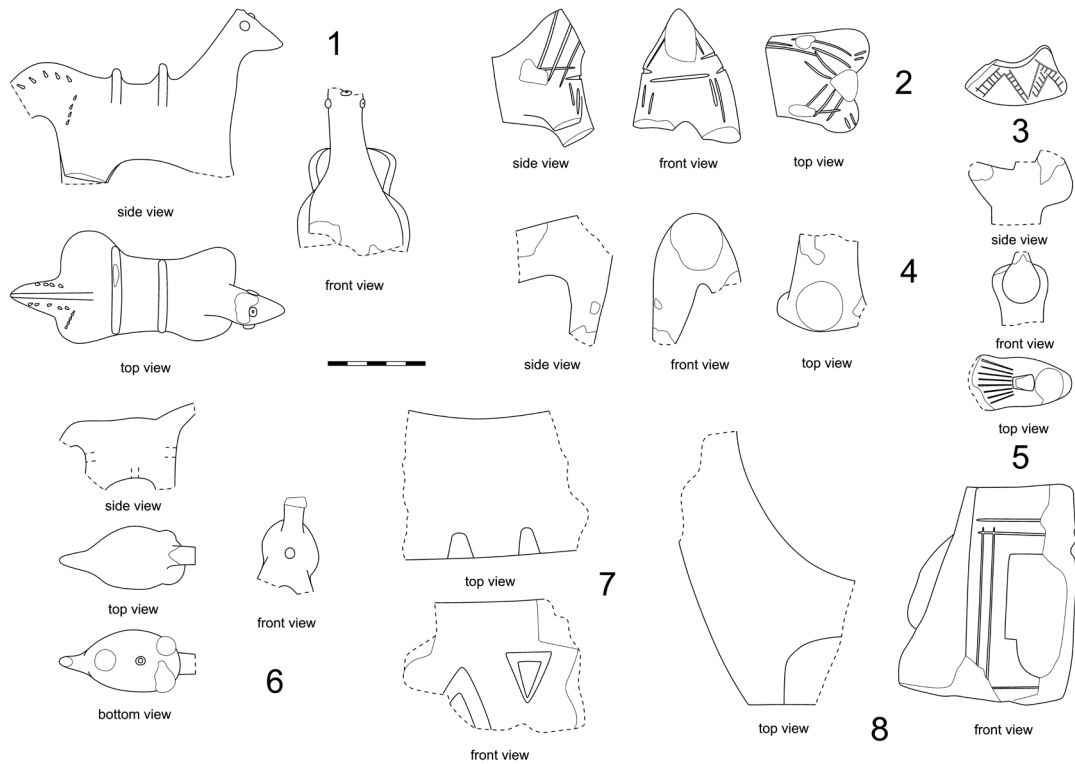

Fig. 24: Terracotta and structural elements (drawing by L. Damašek).

(**Pl. 4/2:10–18; 3:9–14**), geometric decoration in black on a white background composed of dots and lines – a pseudo vegetal motif (**Pl. 4/3:1–4**), and monochrome green glaze (**Pl. 4/2–3**). White opaque glaze with green splashes was present on two shards (**Pl. 4/2:3, 4/3:17**). With only a few exceptions (**Pl. 4/2–3**) almost all the glazed fragments which are big enough to allow determination are from bowls. All the main decoration groups recognized at Lungi Tepa are well known in Central Asia and were detected in material from old Termez. The splashed sgraffiato ware was widespread in Central Asia in the 9th–11th century AD (WILKINSON 1973, group 2; WATSON 2004, F splashed wares 199–203) and was captured in Termez (FERRERAS *et al.* 2020, 261; HOUAL 2021, pl. 256, 84). It was the most numerous (26%, 25 fragments) decorative motif among the glazed ware. The geometric decoration in black on a white background is dated to the 10th–11th century (HOUAL 2021, P3-1251, pl. 79). The monochrome green glaze belongs to two different groups, the fragment from storage pit 39 (**Pl. 4/2:2**) seems like an early variant of the green monochrome glaze which is dimmer. The rest of the fragments (3 pieces) are likely the later variant with a bright surface (**Pl. 4/3:16**). The early variant is usually dated to the 8th–10th century and the later variant is dated to the 11th–12th century (HOUAL 2021, M1 245, pl. 75, M3 247, pl. 75). Within the unglazed (**Fig. 25–27**) ware, one shape stood out, a plate or a lid (unfortunately only the rims are present, not the whole shapes) with an everted rim which is decorated with carved ornaments (**Fig. 25**). These were noticed during the first excavation of Lungi Tepa (BOBOKHOJAEV – ANNAEV – RAKHMANOV 1990, fig. 5:5–8). The closest analogy found are lids from Qashqadaryo with a carved decoration (ISAMIDDINOV – KHASANOV 2000, fig. 30:II, 141). Other unglazed shapes (excluding pottery from storage pit 39) include pots, basins, pitchers, and a storage jar (**Fig. 26, 27**).

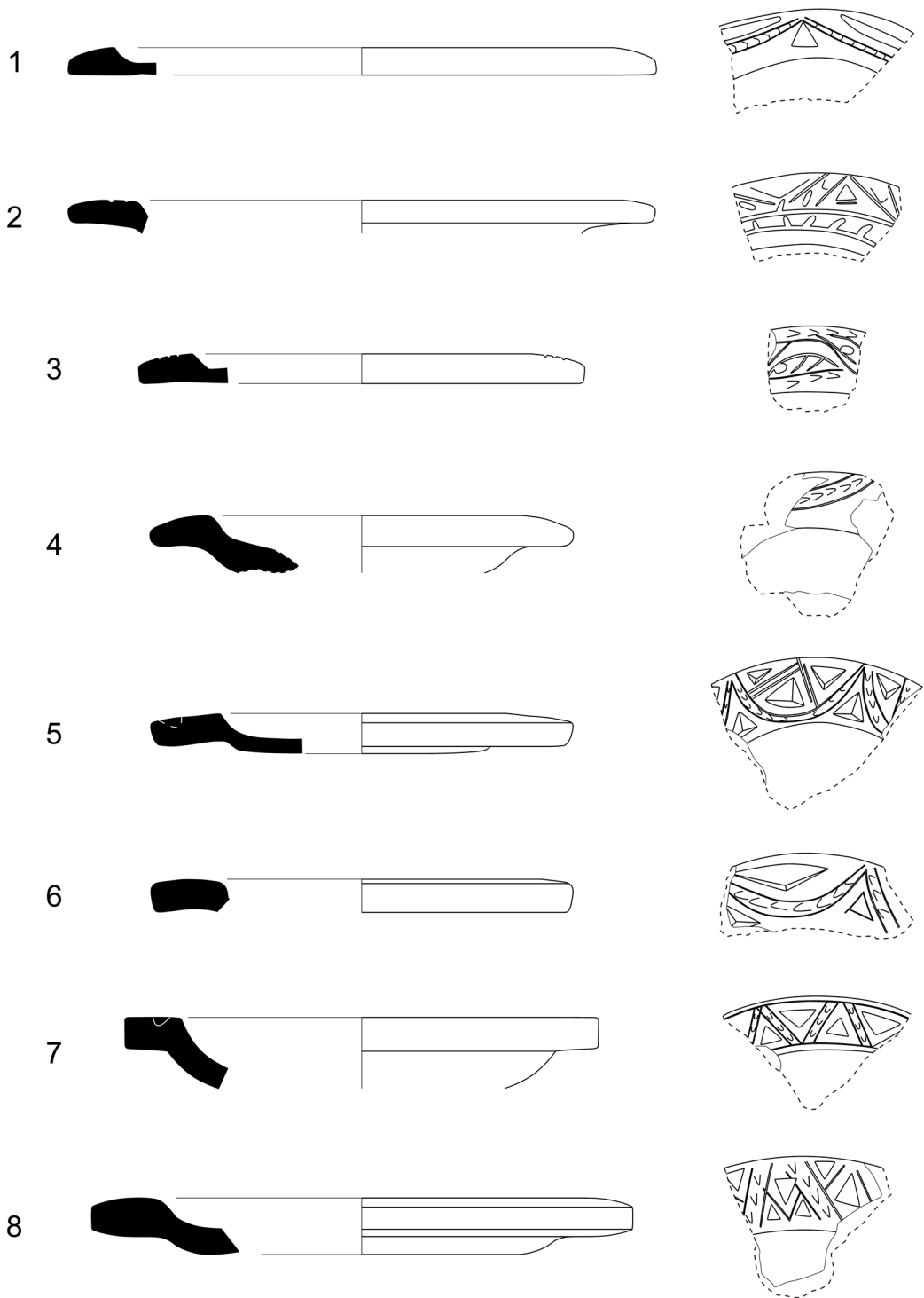

Fig. 25: Pottery phase III - lids/plates (drawing by L. Damašek).

One terracotta figurine was found in the contexts from PIII apart from those from the storage pit (**Fig. 24:2**). The same types of glazed ware were detected in the assemblage in 2021 as in 2019 namely monochrome and polychrome ware.

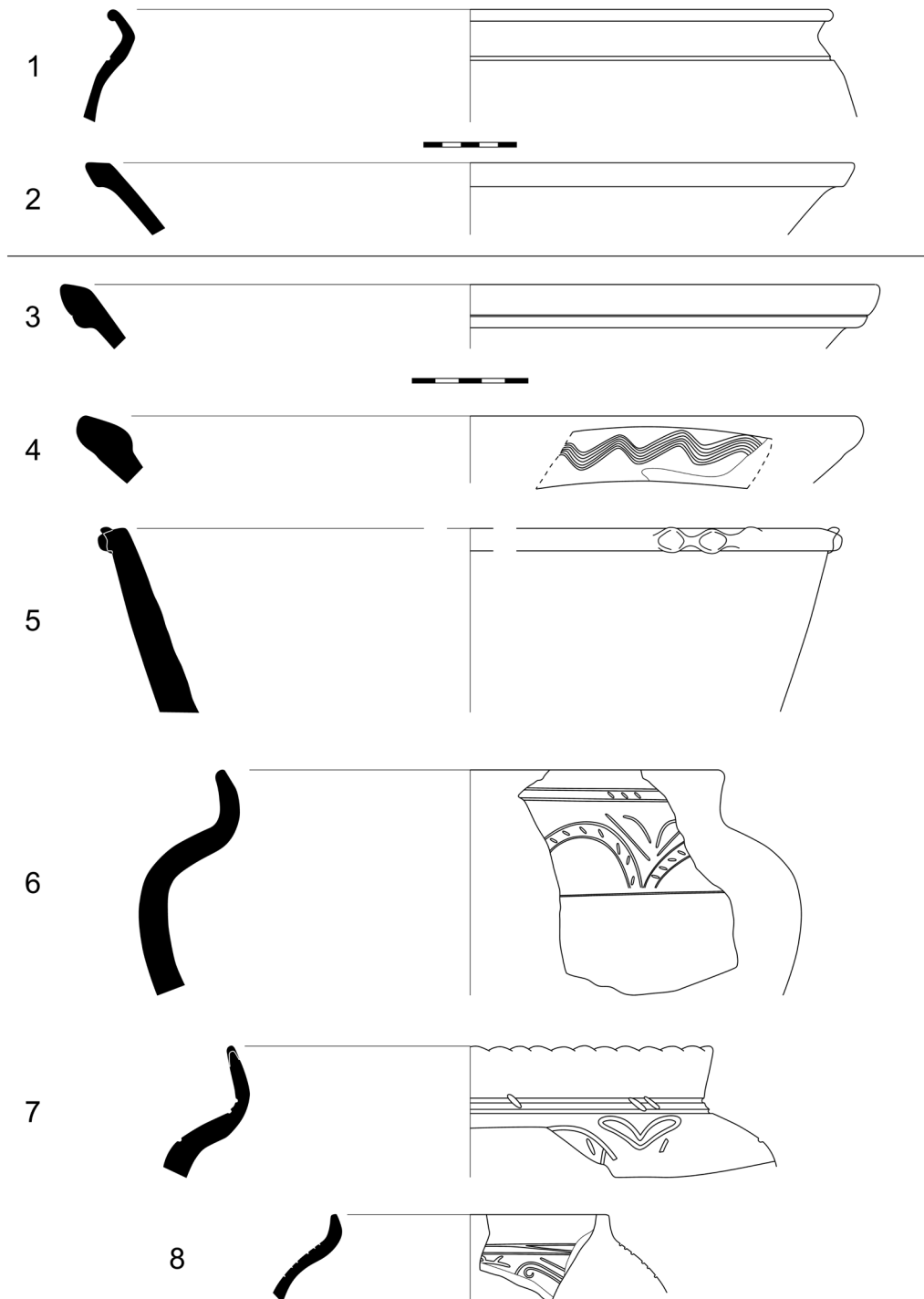

Fig. 26: Pottery phase III (drawing by L. Damašek).

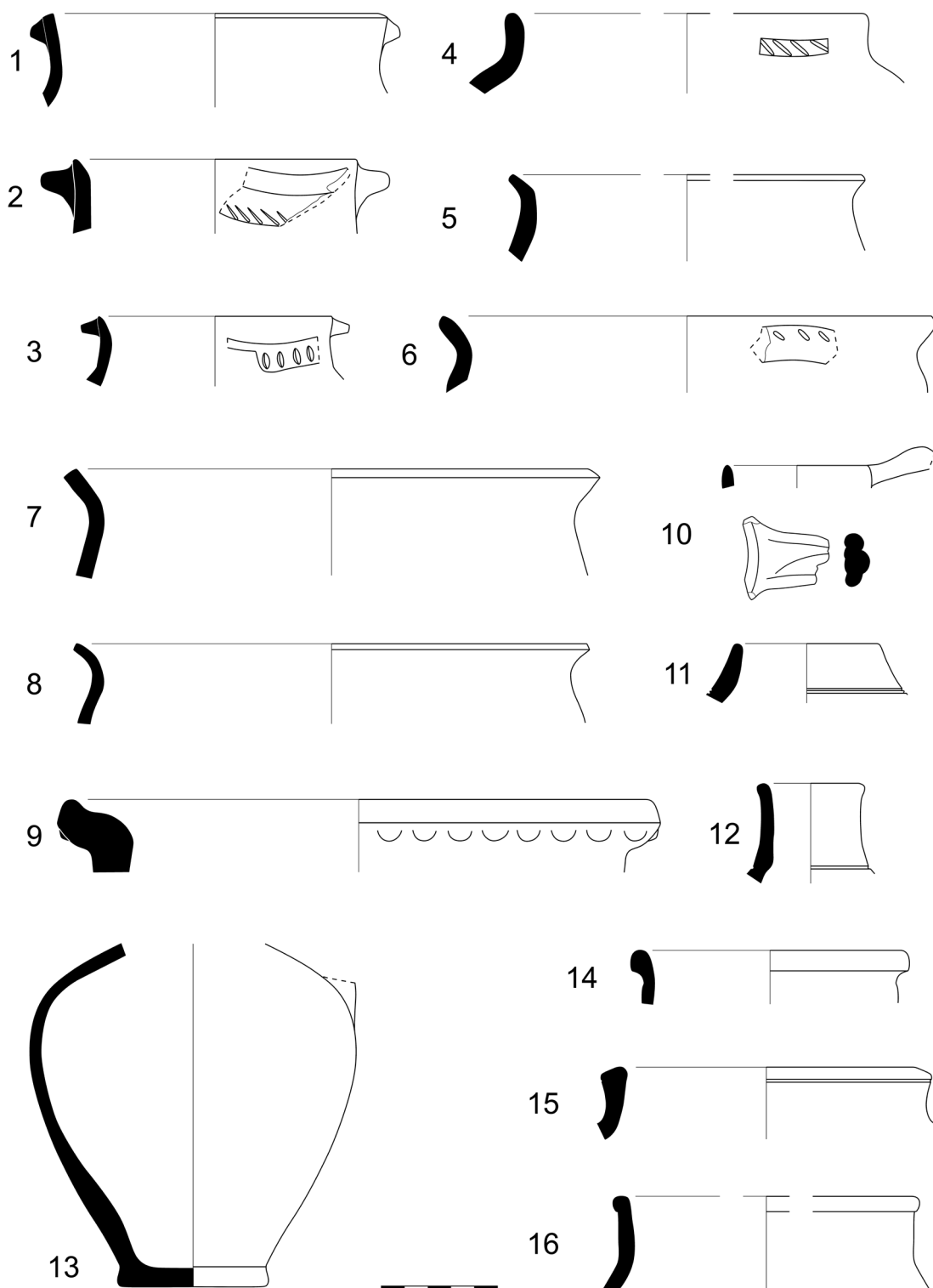

Fig. 27: Pottery phase III (drawing by L. Damašek).

PIV

PIII was followed by PIV. This phase was also established after excavations in 2019 and include features from the pre-Islamic period (Early Medieval period, 5th–8th century AD). Two radiocarbon dates were obtained from material (cow bones) gathered from layer 13 in 2019. Both dates fit in the same span of 650–780 AD (**Fig. 9**). Features from this phase are concentrated in the northern part of S1 closer to the upper part of the main mound and naturally deeper in the body of the main mound. In 2021, the same characteristics as in 2019 came to light. There were not many distinguishable features in phase IV (**Fig. 11, 12**), layers (labelled 33, 41, and 16) were thicker and contained an abundance of animal bone and ceramics. Layers from phase IV were often excavated by spits due to their thickness and abundance of material. Several iron objects were found including a knife, two arrowheads, and a socket (**Tab. 1; Fig. 18:54, 58, 63, 64**). Pottery from phase IV was mainly handmade with a coarse ceramic fabric. Two main groups can be distinguished. Fine ware and coarse ware. The fine ware is wheel thrown whereas the coarse ware is handmade with a lot of inclusions. Among the coarse ware are represented mostly big jugs and pots (**Fig. 28, 29, 30**) which often had traces of use on an open fire. Two almost complete jugs and one partly complete jug were found in layer 33 (**Fig. 28**). Horseshoe-shaped handles, horizontal handles, arched handles, and arched handles with rings in the middle were found in 2019 as well as in 2021 (**Fig. 29**). Rims of storage jars with a brown-red surface were present in the assemblage (**Fig. 29:1–3**). The pottery has similar characteristics as other Early Medieval assemblages from Surxondaryo such as pottery from Dabilkurgan (SOLOVJOV 2013, fig. 8), Shurobkurgan (BOLELOV 2004, 53–61), and other sites

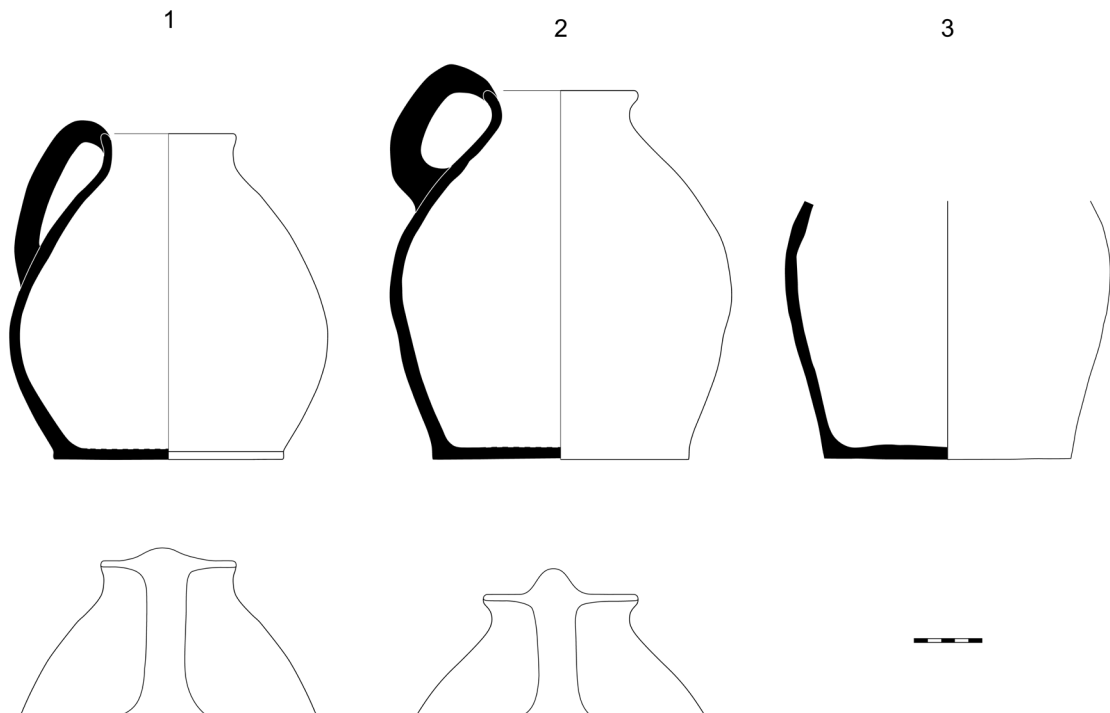

Fig. 28: Pottery phase IV – jugs (drawing by L. Damašek).

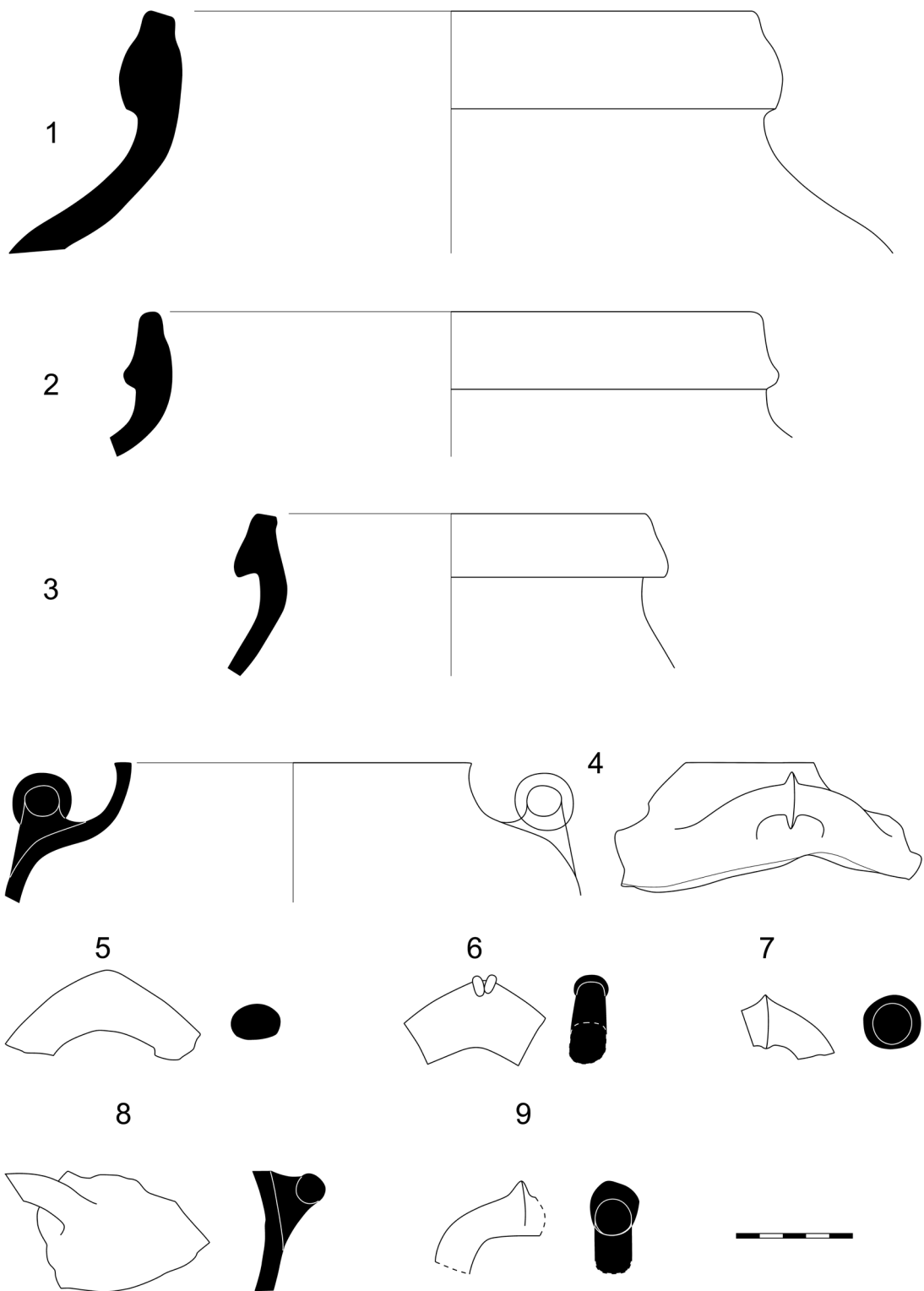

Fig. 29: Pottery phase IV - pots (drawing by L. Damašek).

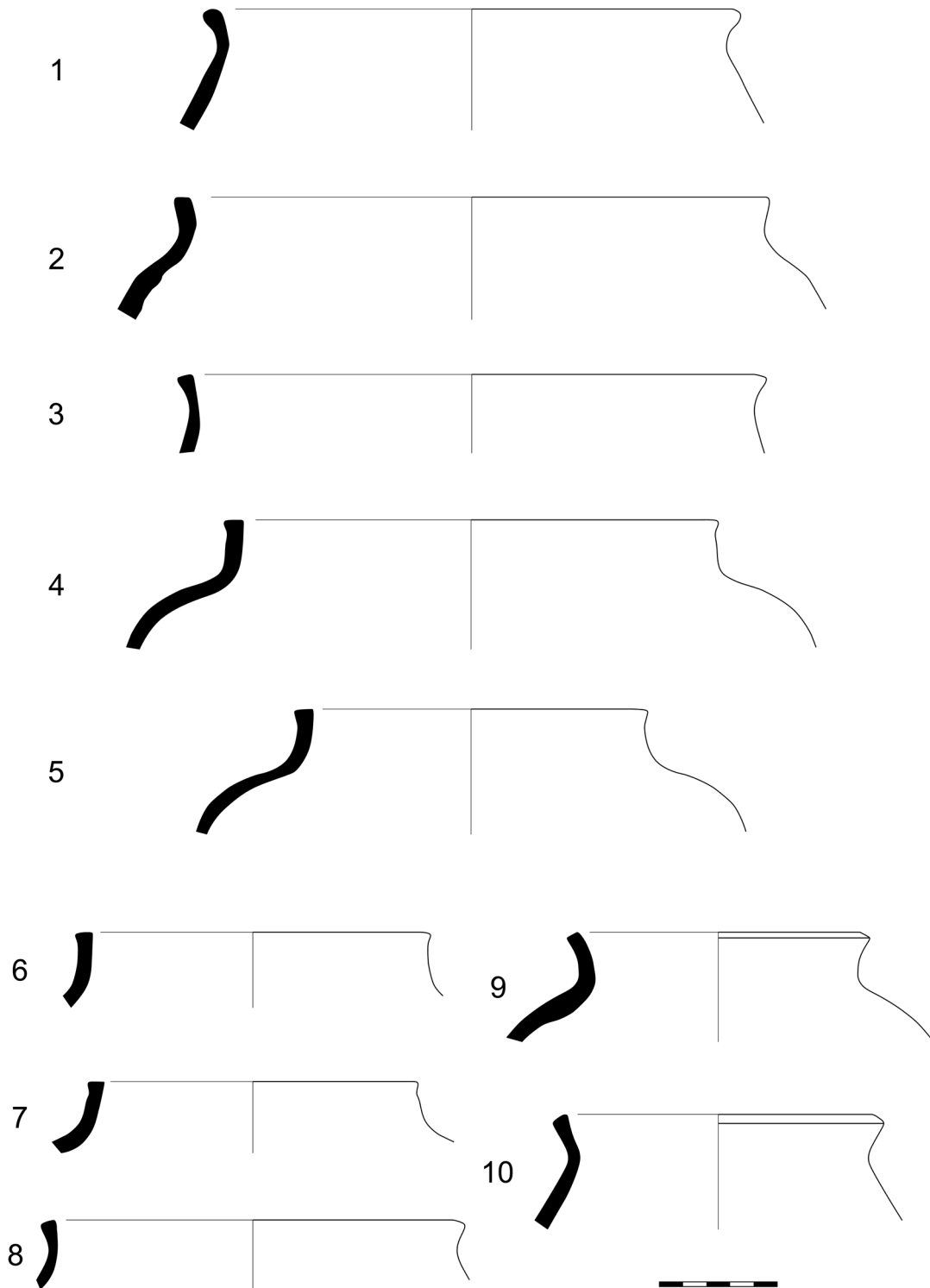

Fig. 30: Pottery phase IV - pots (drawing by L. Damašek).

(ANNAEV 1988, tab. I-XVII). An interesting fragment of pottery which is most probably Early Medieval was found in layer 24 (phase III). It has well processed clay and it is decorated with a stamp in the form of a stylised human face (Pl. 4/1:14). Analogies to this type of stamped decoration can be found in pottery from the 5th–7th century AD (MARSHAK 2012, 356).

PV

In 2021, a new phase V was recognised. This phase was distinguished based on the stratigraphy and change in character of layers and composition of ceramics. Features from this phase V (layers labelled 36 and 44) were concentrated in the northern part of S1 and they represented the deepest uncovered archaeological situations (Fig. 11, 12). The subsoil was only reached in the southern part of S1 near the base of the tell mound, so phase V remains the last recorded unit. It is not likely, but the possibility of another phase or phases following PV cannot be excluded, since the subsoil was not reached in the northern part of S1 below PV. In terms of absolute dating, phase V can be dated to the post-Kushan period/Kushan-Sasanian period (3rd–5th century AD). This dating is indicative and needs to be confirmed by exact dating methods. The layers and other features of this phase contain fewer artefacts compared to the rest of the stratigraphy. They almost lack any material except pottery which was sparser compared to the layers belonging to phases III and IV. Layer 44 did not contain any artefacts.

An important characteristic of phase V is that it contains big fragments of storage jars, both in clusters and isolated (Fig. 31). This is the case of layer 36 which must have been accumulated in a short period of time because some of the bigger fragments of storage jars (approximately 30–40 cm) were in a vertical position. It is clearly visible on the northern wall of baulk K1 (Fig. 32). All the layers of PV were also compacted and hard to dig using finer tools. In some cases, a pickaxe had to be used. The only noticeable feature in PV was a small oven covered from the sides by fragments of storage jars (Fig. 33). It is hard to determine the purpose of this



Fig. 31: Fragments of storage jars (photo by L. Damašek).

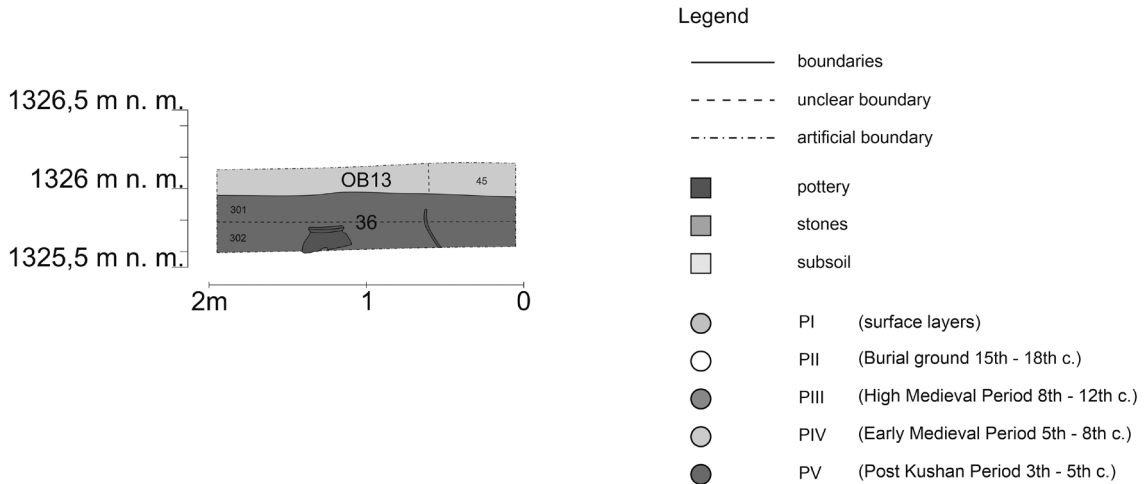

Fig. 32: profile K1 - north (drawing by L. Damašek).



Fig. 33: Small oven (photo by D. Pilarř).

oven. It was definitely not a furnace or a kiln because the soil around it did not bear any traces of exposure to high temperatures for a longer period of time such as burned or vitrified clay. In the vicinity of the oven an iron ring, an iron coil and a copper sheet were found (**Tab. 1; Fig. 18:59, 60, 105**). Underneath layer 44 a hollow space was discovered. Because it was a dead end of a longer tunnel it was interpreted as a burrow (**Fig. 34**). The collection of pottery from PV is rather small compared to the other phases. It is dominated by the fragments of storage jars. From the rest of the assemblage, fragments decorated by burnishing (**Pl. 4/1:11-13**) and red or reddish and black engobe (**Pl. 4/1:16-22**) stand out. These fragments belong to wheel thrown vessels (tableware) with well processed clay. Also, a fragment with stamped palmettes was found (**Pl. 4/1:15**). This pottery was the main reason why phase V was dated to the post-Kushan/Kushan-Sasanian period. An analogy can be found in the assemblage from old Termez (HOVAL 2021, 56-60). In layer 36 a zoomorphic rattle was found (**Fig. 24:6**).



Fig. 34: Burrow (photo by L. Damašek).

EVIDENCE OF METALLURGY

Artefacts associated with metal production were found in the material from Lungi Tepa. These were metallurgical slag, blacksmith slag, ironwork intermediate product and vitrified clay (Tab. 1; Fig. 35). The amount of these artefacts is too small to consider production facilities at the site. In the case of metallurgical slags, they are usually present in high amounts in the places of production. Based on these artefacts we can assume that the production and processing of iron was conducted in the vicinity of Lungi Tepa.

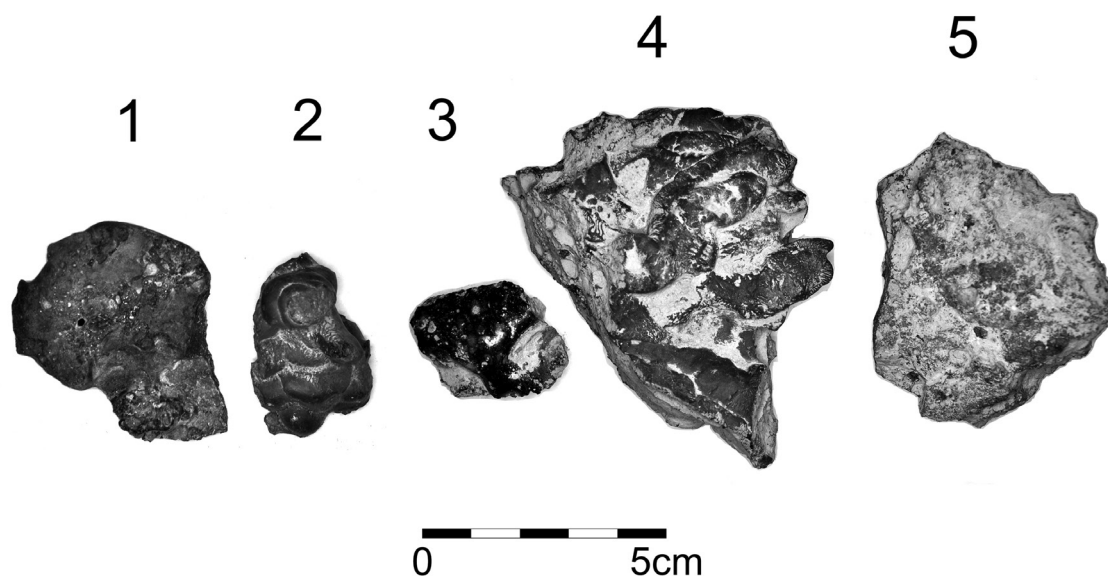

Fig. 35: Slag (photo by M. Kmošek).

Tab. 1: Small Finds.

| Code | Phase/context | material | object |
|------|---------------|---------------------------------|-----------|
| 45 | PI/001 | copper | coin |
| 46 | PI/001 | tin-lead alloy | pendant |
| 51 | PI/001 | leaded bronze | coin |
| 52 | PI/001 | iron | fitting |
| 56 | PI/001 | iron | fitting |
| 77 | PI/001 | iron smelting slag | - |
| 95 | PI/001 | glass | fragment |
| 78 | PI/001 | iron smelting slag | - |
| 50 | PI/002 | leaded copper | coin |
| 53 | PI/002 | iron | hook |
| 76 | PI/002 | iron | fragment |
| 48 | PII/022 | iron | rod |
| 67 | PII/022 | iron smelting slag | - |
| 98 | PII/022 | glass | fragment |
| 99 | PII/026 | glass | fragment |
| 62 | PIII/011 | iron | fragment |
| 68 | PIII/020 | iron smelting slag | - |
| 73 | PIII/024 | iron smelting slag | - |
| 69 | PIII/032 | iron smelting slag/slugged clay | - |
| 70 | PIII/032 | iron smelting slag/glassed clay | - |
| 72 | PIII/032 | iron smelting slag | - |
| 75 | PIII/037 | iron smelting slag | - |
| 57 | PIII/110 | iron | arrowhead |
| 47 | PIII/200 | iron | rod |
| 49 | PIII/200 | leaded bronze | rod |
| 101 | PIII/200 | glass | rim |
| 55 | PIII/201 | iron | belt part |
| 97 | PIII/201 | glass | fragment |
| 100 | PIII/201 | glass | rim |
| 103 | PIII/201 | glass | bead |
| 128 | PIII/201 | semi-precious gemstone | bead |
| 129 | PIII/202 | semi-precious gemstone | bead |
| 74 | PIII/400 | iron smelting slag | - |
| 107 | PIII/400 | iron smelting slag | - |
| 119 | PIII/501 | slugged clay | - |
| 121 | PIII/502 | nacre | - |
| 124 | PIII/503 | iron smelting slag | - |
| 81 | PIII/OB8 | iron smelting slag/slugged clay | - |
| 96 | PIII/OB8 | glass | fragment |
| 102 | PIII/V14 | glass | fragment |
| 66 | PIV/013 | iron | fragment |
| 54 | PIV/015 | iron | arrowhead |

| Code | Phase/context | material | object |
|------|---------------|--------------------------------------|-----------|
| 79 | PIV/015 | iron smelting slag/iron semi-product | - |
| 58 | PIV/016 | iron | arrowhead |
| 108 | PIV/041 | iron smelting slag | - |
| 61 | PIV/101 | iron | fragment |
| 63 | PIV/101 | iron | socket |
| 64 | PIV/101 | iron | knife |
| 80 | PIV/OB13 | slagged clay | - |
| 60 | PV/035 | iron | coil |
| 59 | PV/036 | iron | ring |
| 105 | PV/036 | copper | sheet |
| 106 | PV/036 | iron | fragment |

DISCUSSION

An interesting phenomenon was noticed in the stratigraphy. There is a difference between the contexts from the High and Early Middle Ages. The Early Medieval contexts (phase IV) are rich in ash, charcoal, animal bones and contain large fragments of pottery or even whole fragmented vessels, whereas the only High Medieval component (phase III) with a similar composition is the storage pit 39. Other High Medieval contexts are different: they do not contain ash, charcoal, and animal bones are much less common. The pottery is more fragmented with very rare cases of shards that can be put together. It seems like there is a difference in waste management between these two periods. It looks like in the Early Medieval period the waste accumulated directly at the site, whereas in the High Medieval period a different approach to refuse management prevailed. The only context from the High Medieval period which can be interpreted as waste accumulation is the filling of the storage pit 39. We have to keep in mind that it is a very limited part of the whole settlement from which the conclusion is drawn. As the research of Medieval sites continue, it will be interesting to see whether this phenomenon repeats elsewhere showing a pattern, or it is just an isolated case and thus more likely an outcome of the limited view provided by the narrow stratigraphic cut.

After the first season (2019) an absence of metal findings in contexts except those of phase I was discussed (DAMAŠEK *et al.* 2020, 175–176). Even if in season 2021 we encountered some metal findings, they concentrated mostly in surface layers – phase I (**Tab. 1**). In phase III, the metal findings (5 pieces) come almost exclusively from the storage pit 39 (3 pieces). Phase IV contained only 6 and phase V just 3 iron objects. To sum up, there are some metal finds, but the amount of them is low especially when we take into consideration that there are traces of iron production at the site.

CONCLUSION

In addition to the Early (5th–8th century AD) and High (8th–13th century AD) Medieval phases established in 2019, a new phase dating to the post-Kushan period/Kushan-Sasanian period (3rd–5th century AD) was attested in 2021. As a result, the settlement of the main mound of Lungi

Tepa expands to an interval of roughly the 3rd–13th century AD. Four graves were uncovered, all belonging to the same burial horizon as the eight graves found in 2019 spanning from the 15th to 17th century AD. Several radiocarbon dates were obtained to anchor the stratigraphy of the site. An attempt was made to roughly date the platform surrounding the main mound but it was not successful and remains to be done in the future. Traces of metallurgy were found in the material from the main mound. These materials will be further analysed and published separately.

After two seasons of research, we can summarize that Lungi Tepa is a good example of a foothill settlement of the Early to High Middle Ages. The site was used repeatedly and even in the Late Medieval period the settlement must have been located in its vicinity because a lot of pottery from this time period was collected from the surface layers of trench S1 and from the platform (DAMAŠEK *et al.* 2020, 163–164). In a typical manner for the area, the site was later used as a burial ground. This phenomenon is attested at many other sites, such as for example Sabir Archa in Khatak, Kurgan Tepa in Karabag, etc. The nature of the excavation does not allow for an assessment of the settlement type or its layout and main features. On the other hand, its material culture allows us to gain a good insight into the craft production of peripheral settlements in contrast to that of the major urban centres of these periods. Further research may also confirm the importance of metalworking as a motivating factor for the establishment of similar settlements in the foothills and for their long-term existence.

ACKNOWLEDGEMENTS

This paper was written as a part of a project ‘From the Arabs to Genghis Khan. Chronology and typology of the High Medieval pottery in the mountain and foothill areas of Surkhandarya, southern Uzbekistan’ financed by Charles University Grant Agency (GAUK) project number 106222. We are grateful to Jiří Sejkora from the Department of Mineralogy and Petrology, National Museum, Prague. He provided Raman microspectroscopy analyses of the two stone beads and also their microscopic determination. Huge thanks go to Matěj Kmošek who studied and determined all the metal objects and the slags. The radiocarbon dating of burials H4 and H5 and cow bones (samples: Wk-51757; Wk-51758; Wk-51897; WK-51898) was done by The Waikato Radiocarbon Dating Laboratory. Radiocarbon dating was conducted within University of Otago Out of Season Research Grant ‘Human health and adaptation along Silk Roads a bioarchaeological investigation of a Medieval Uzbek cemetery’

BIBLIOGRAPHY

- ABDULLAYEV 1998 = Абдуллаев, К.: Художественное стекло старого термеза. *История материальной культуры Узбекистана* 29, 129–137.
- АННАЕВ 1988 = Аннаев, Т.Д.: *Раннесредневековые Поселения Северного Тохаристана*. Ташкент.
- AUGUSTINOVÁ *et al.* 2016 = Augustinová, A. – Stančo, L. – Shaydullaev, S. – Mrva, M.: Archaeological Survey in the Zarabag Micro Oasis (South Uzbekistan), Preliminary Report on the Season 2015. *Studia Hercynia* 19/1-2, 262–281.
- ВОВОКНОЈАЕВ – АННАЕВ – РАКНМАНОВ 1990 = А. Бобохаджаев – Т. Аннаев – Ш. Рахманов: Некоторые итоги изучения древних и средневековых памятников предгорной и горной полосы Кугитанг-Байсунтау. *История материальной культуры Узбекистана* 23, 25–36.

- BOLELOV 2004 = Болелов, С.Б.: Археологические исследования на городе Шуробкургане в 1982 году (к истории материальной культуры северного Тохаристана в эпоху раннего средневековья). *Материалы Тохаристанской Экспедиции, выпуск 4*, 10–62.
- DAMAŠEK *et al.* 2020 = Damašek, L. – Kinaston, R. – Kramer, R. – Šmolková, M. – Pilař, D. – Shaydullaev, S. – Stančo, L.: Archaeological excavations at Lungi Tepe, south Uzbekistan. Preliminary Report for Season 2019. *Studia Hercynia* 24/1, 159–178.
- DAMAŠEK, L. 2019: *Dynamika osídlení Tocharistánu ve vrcholném středověku a její příčiny*. Unpublished MA thesis, Charles University. Praha.
- FERRERAS *et al.* 2020 = V.M. Ferreras – A. Fusaro – J.M.G. Esparraguera – E.A. Gil – S.R. Pidaev – A. Angourakis: The Islamic Ancient Termez Through the Lens of Ceramics. A New Archaeological and Archaeometric Study. *Iran* 58/2, 250–278.
- HOUAL, J.B. 2021: *La céramique antique et médiévale de Termez et Khaitabad (Ouzbékistan)*. Paris.
- ISAMIDDINOV – KHASANOV 2000 = Исамиддинов М.Х. – Хасанов М.Х.: *История древнего и средневекового керамического производства Нахшаба*. Ташкент.
- KRÖGER, J. 1995: *Nishapur. Glass of the early Islamic period*. New York.
- MARSHAK 2012 = Маршак, Б.И.: *Керамика Созда V–VII веков как историко-культурный памятник (к методике изучения керамических комплексов)*. Санкт-Петербург.
- МОКРОВОРОДОВ 2007 = Мокророводов, В.В.: Исследование подземного жилого комплекса Бури Кабир в 2004 г. *Труды Байсунской научной экспедиции* 3, 20–29.
- ŠEJKO 2011 = Шейко, К.: Крепость Мунчак-тепа в Сайробе. *Материалы Тохаристанской экспедиции* 8, 227–244.
- SOLOVJOV 2013 = Соловьёв, В.С.: Раскопки на объекте V Дабилькуркана в 2010–2013 гг. *Материалы Тохаристанской экспедиции* 9, 33–83.
- STANČO *et al.* 2017 = Stančo, L. – Shaydullaev, S. – Shaydullaev, A. – Augustinová, A. – Havlík, J. – Cejnarová, P.: Archaeological Survey in the eastern Kugitang Piedmonts (South Uzbekistan), Preliminary Report for Seasons 2016 and 2017. *Studia Hercynia* 21/2, 121–138.
- STANČO, L. 2019: *Living at the Iron Gates. New research on the settlement pattern in the Bactria – Sogdiana borderlands*. Unpublished talk delivered at the International Seminar on Archaeology of Central Asia, 14 January 2019, Vilnius.
- STRIDE, S. 2004: *La Géographie Archéologique de la Province du Surkhan Darya (Bactriane du Nord, Ouzbékistan du Sud)*. Unpublished dissertation at the Université Panthéon-Sorbonne. Paris.
- WATSON, O. 2004: *Ceramics from Islamic lands*. London.
- WILKINSON, C.K. 1973: *Nishapur. Pottery of the early Islamic period*. New York.

Ladislav Damašek

Institute of Classical Archaeology
Faculty of Arts, Charles University
Celetná 20, Prague 1, CZ-110 00
ladislav.damasek@seznam.cz

Shapulat Shaydullaev

Termez State University
42, Fayzulla Khojaev
Termez, Uzbekistan, 190100
shapulat@mail.ru

Daniel Pilař

Samuel Kertés
Institute of archaeology
Faculty of Arts, Charles University
Celetná 20, Prague 1, CZ-110 00

Institute of Archaeology of the CAS, Prague, v. v. i.
Letenská 4, 118 00 Prague 1
pilar@arup.cas.cz
kertes@arup.cas.cz

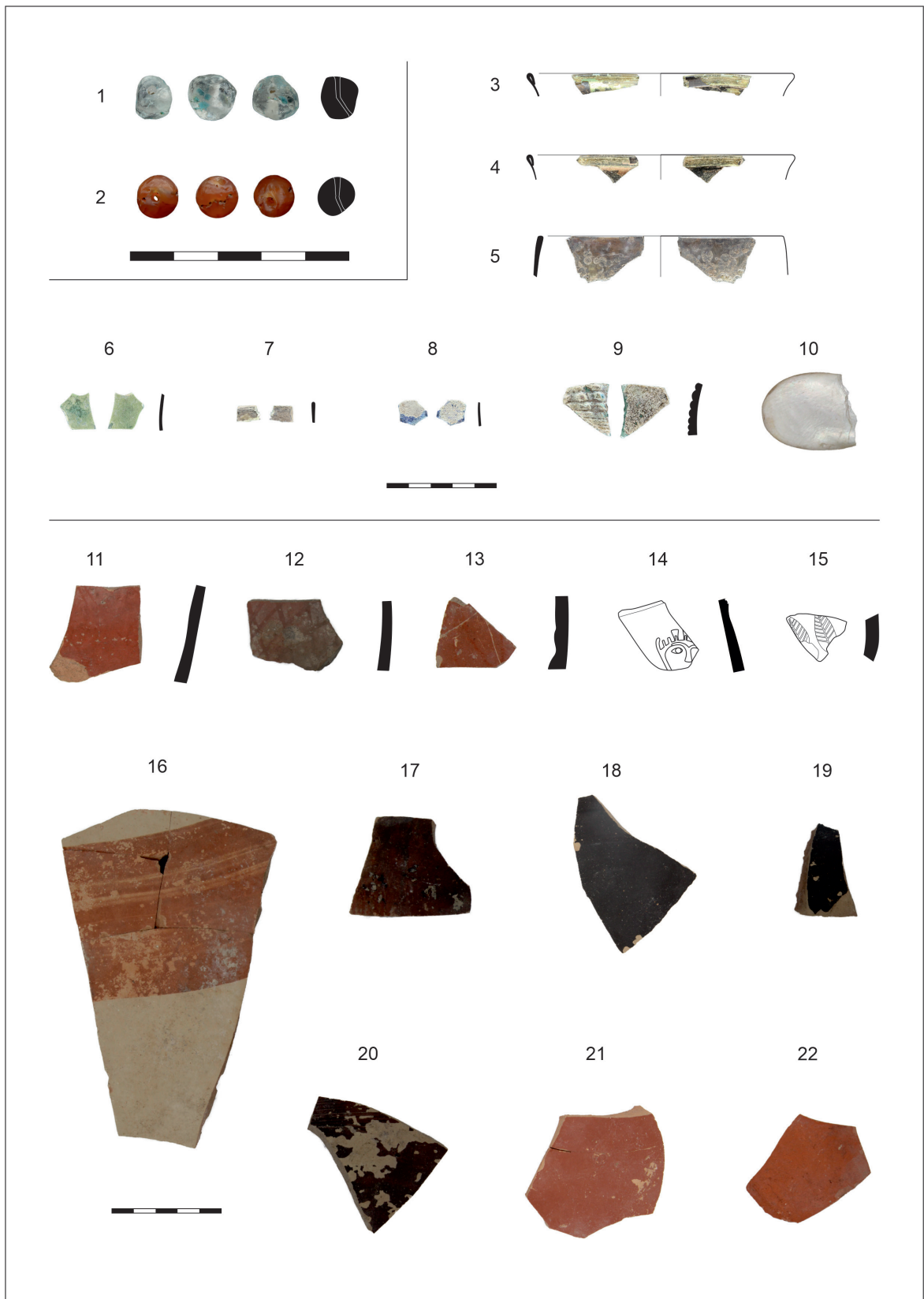

Pl. 4/1: Glass and pottery (drawing by L. Damašek; photo by S. Kertés).

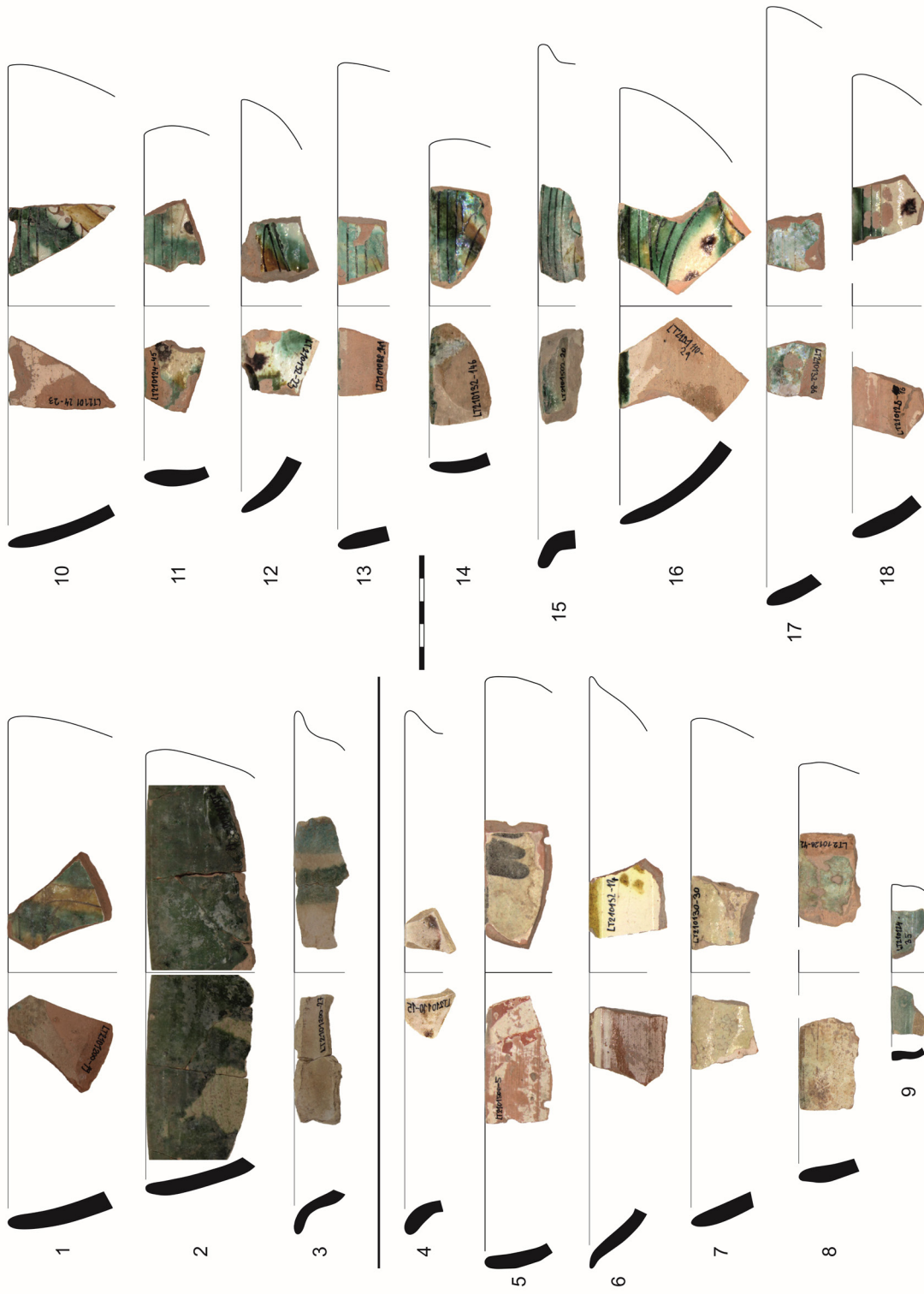

Pl. 4/2: Glazed pottery (drawing by L. Damašek; photo by S. Kertés).

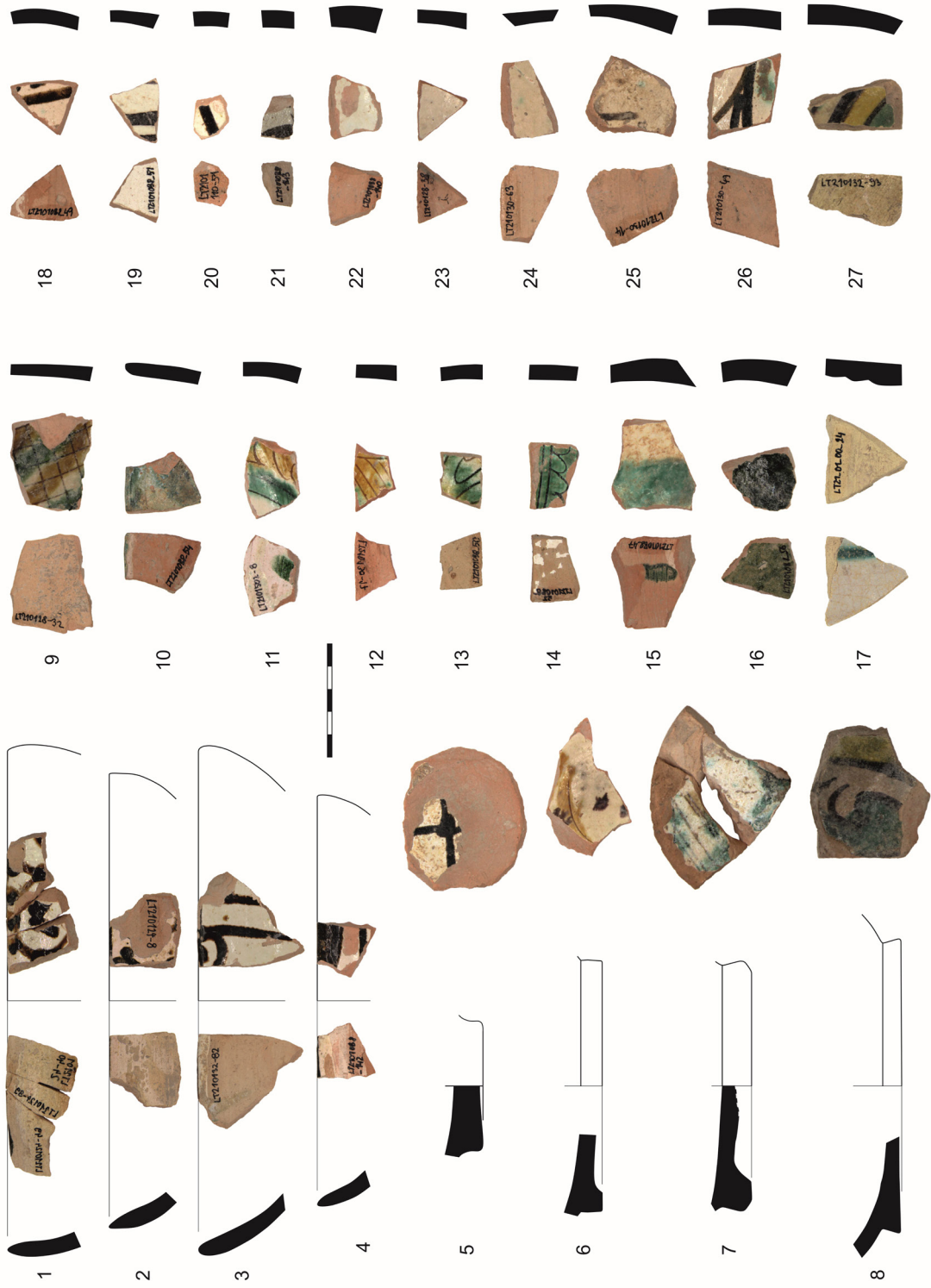

Pl. 4/3: Glazed pottery (drawing by L. Damašek; photo by S. Kertész).